



SERVICE MANUAL

VHF MARINE TRANSCEIVER

IC-M505

S-14226HZ-C1

May. 2006

Icom Inc.

INTRODUCTION

This service manual describes the latest service information for the **IC-M505 MARINE TRANSCEIVER** at the time of publication.

MODEL	VERSION	SYMBOL	COLOR
IC-M505	Europe	[EUR]	Black
		[EUR-01]	Gray
	U.K	[UK]	Black
		[UK-01]	Gray
	Holland	[HOL]	Black
	Germany	[FRG]	Black

To upgrade quality, all electrical or mechanical parts and internal circuits are subject to change without notice or obligation.

PRECAUTIONS

NEVER connect the transceiver to an AC outlet or to a DC power supply that uses more than 16 V. Such a connection could cause a fire or electric hazard.

DO NOT expose the transceiver to rain, snow or any liquids.

DO NOT reverse the polarities of the power supply when connecting the transceiver.

DO NOT apply an RF signal of more than 20 dBm (100 mW) to the antenna connector. This could damage the transceiver's front end.



ORDERING PARTS

Be sure to include the following four points when ordering replacement parts:

1. 10-digit Icom parts number
2. Component name and informations
3. Equipment model name and unit name
4. Quantity required

<SAMPLE ORDER>

1130007611 S.IC μPD3140GSA IC-M505 Main unit 5 pieces
8810010610 Screw PH B0 M3×8 SUS IC-M505 Chassis 10 pieces

Addresses are provided on the inside back cover for your convenience.

REPAIR NOTES

1. Make sure the problem is internal before disassembling the transceiver.
2. **DO NOT** open the transceiver until the transceiver is disconnected from its power source.
3. **DO NOT** force any of the variable components. Turn them slowly and smoothly.
4. **DO NOT** short any circuits or electronic parts. An insulated turning tool **MUST** be used for all adjustments.
5. **DO NOT** keep power ON for a long time when the transceiver is defective.
6. **DO NOT** transmit power into a signal generator or a sweep generator.
7. **ALWAYS** connect a 40 dB to 50 dB attenuator between the transceiver and a deviation meter or spectrum analyzer when using such test equipment.
8. **READ** the instructions of test equipment thoroughly before connecting equipment to the transceiver.

Icom, Icom Inc. and ICOM logo are registered trademarks of Icom Incorporated (Japan) in the United States, the United Kingdom, Germany, France, Spain, Russia and/or other countries.

TABLE OF CONTENTS

SECTION 1	SPECIFICATIONS	
SECTION 2	INSIDE VIEWS	
SECTION 3	DISASSEMBLY INSTRUCTIONS	
SECTION 4	CIRCUIT DESCRIPITON	
4-1	RECEIVER CIRCUITS.	4-1
4-2	TRANSMITTER CIRCUITS.	4-2
4-3	PLL CIRCUITS.	4-4
4-4	DSC CIRCUITS.	4-5
4-5	POWER SUPPLY CIRCUITS.	4-5
4-6	PORT ALLOCATIONS.	4-5
SECTION 5	ADJUSTMENT PROCEDURES	
5-1	PREPARATION.	5-1
5-2	FREQUENCY ADJUSTMENT.	5-2
5-3	TRANSMIT ADJUSTMENT.	5-3
5-4	RECEIVE ADJUSTMENT.	5-4
SECTION 6	PARTS LIST	
SECTION 7	MECHANICAL PARTS AND DISASSEMBLY	
SECTION 8	SEMICONDUCTOR INFORMATION	
SECTION 9	BOARD LAYOUTS	
9-1	AF UNIT.	9-1
9-2	MAIN UNIT.	9-1
9-3	HM-126B-3/G.	9-3
9-4	VR BOARD.	9-3
9-5	SQL BOARD.	9-3
9-6	DIAL BOARD.	9-3
9-7	LOGIC BOARD.	9-3
SECTION 10	BLOCK DIAGRAM	
SECTION 11	VOLTAGE DIAGRAM	
11-1	FRONT UNIT (inc. LOGIC/DIAL/SQL/VR BOARD's).	11-1
11-2	AF UNIT.	11-2
11-3	MAIN UNIT.	11-3

SECTION 1 SPECIFICATIONS

■ GENERAL

- Frequency coverage : TX 156.000–161.450 MHz
RX 156.000–163.425 MHz
CH70 RX 156.525 MHz
- Type of emission : 16K0G3E (FM), 16K0G2B (DSC)
- Antenna impedance : 50 Ω (Nominal)
- Operating temperature range : –20°C to +60°C
- Power supply requirement : 13.8 V DC (10.8–15.6 V; negative ground)
- Current drain (At 13.8 V DC) : TX 5.5 A (at 25 W)
RX 1.5 A (at max. audio)
- Dimensions (Projections not included) : 165 (W)×110 (H)×123.2 (D) mm
- Weight (Approx.) : 1450 g

■ TRANSMITTER

- Output power : 25 W (High)/1 W (Low)
- Modulation : Variable reactance frequency modulation
- Maximum frequency deviation : ± 5.0 kHz
- Frequency error : Less than ± 1.5 kHz
- Spurious emissions : Less than 0.25 μ W
- Adjacent channel power : More than 70 dB
- Audio harmonic distortion : Less than 10% (at 60% deviation)
- Residual modulation : More than 40 dB
- Audio frequency response : +1 dB to –3 dB of 6 dB oct. from 300 Hz to 3000 Hz
- Microphone impedance : 2 k Ω

■ RECEIVER

- Receive system : Double conversion superheterodyne system
- Intermediate frequencies : 1st IF: 21.7 MHz, 2nd IF: 450 kHz (FM RX)
1st IF: 31.05 MHz, 2nd IF: 450 kHz (DSC RX)
- Sensitivity : –5 dB μ emf typ. at 20 dB SINAD
- Squelch sensitivity : Less than 0 dB μ emf
- Adjacent channel selectivity : More than 73 dB (FM RX)
More than 70 dB (DSC RX)
- Spurious response : More than 73 dB (FM RX)
More than 70 dB (DSC RX)
- Intermodulation rejection ratio : More than 73 dB (FM RX)
More than 68 dB (DSC RX)
- Hum and Noise : More than 40 dB
- Audio frequency response : +1 dB to –3 dB of –6 dB oct. from 300 Hz to 3000 Hz
- Audio output power : More than 2 W at 10% distortion with a 4 Ω load
- Audio output impedance : 4 Ω

Specifications are measured in accordance with EN301 025-2, -3

All stated specifications are subject to change without notice or obligation.

• Channel list

• International channels

CH	Frequency (MHz)		CH	Frequency (MHz)		CH	Frequency (MHz)		CH	Frequency (MHz)		CH	Frequency (MHz)		CH	Frequency (MHz)	
	Transmit	Receive		Transmit	Receive		Transmit	Receive		Transmit	Receive		Transmit	Receive		Transmit	Receive
01	156.050	160.650	11	156.550	156.550	21	157.050	161.650	61	156.075	160.675	71	156.575	156.575	81	157.075	161.675
02	156.100	160.700	12	156.600	156.600	22	157.100	161.700	62	156.125	160.725	72	156.625	156.625	82	157.125	161.725
03	156.150	160.750	13	156.650	156.650	23	157.150	161.750	63	156.175	160.775	73	156.675	156.675	83	157.175	161.775
04	156.200	160.800	14	156.700	156.700	24	157.200	161.800	64	156.225	160.825	74	156.725	156.725	84	157.225	161.825
05	156.250	160.850	15* ¹	156.750	156.750	25	157.250	161.850	65	156.275	160.875	75* ³	156.775	156.775	85	157.275	161.875
06	156.300	156.300	16	156.800	156.800	26	157.300	161.900	66	156.325	160.925	76* ³	156.825	156.825	86	157.325	161.925
07	156.350	160.950	17* ¹	156.850	156.850	27	157.350	161.950	67	156.375	156.375	77	156.875	156.875	87	157.375	157.375
08	156.400	156.400	18	156.900	161.500	28	157.400	162.000	68	156.425	156.425	78	156.925	161.525	88	157.425	157.425
09	156.450	156.450	19	156.950	161.550	37A* ²	157.850	157.850	69	156.475	156.475	79	156.975	161.575	P4* ²	161.425	161.425
10	156.500	156.500	20	157.000	161.600	60	156.025	160.625	70 [†]	156.525	156.525	80	157.025	161.625			

[†] DSC operation only.

*¹ Channels 15 and 17 may also be used for on-board communications provided the effective radiated power does not exceed 1 W, and subject to the national regulations of the administration concerned when these channels are used in its territorial waters.

*² UK Marina Channels: M1=37A (157.850 MHz), M2=P4 (161.425 MHz) for U.K. version only

*³ The use of these channels should be restricted to navigation-related communications only and all precautions should be taken to avoid harmful interference to channel 16, e.g. by limiting the output power to 1 W or by means geographical separation.

• USA channels (for U.K. version only)

CH	Frequency (MHz)		CH	Frequency (MHz)		CH	Frequency (MHz)		CH	Frequency (MHz)		CH	Frequency (MHz)		CH	Frequency (MHz)	
	Transmit	Receive		Transmit	Receive		Transmit	Receive		Transmit	Receive		Transmit	Receive		Transmit	Receive
01A	156.050	156.050	12	156.600	156.600	22A	157.100	157.100	64A	156.225	156.225	75* ¹	156.775	156.775	85	157.275	161.875
--	---	---	13* ²	156.650	156.650	23A	157.150	157.150	65A	156.275	156.275	76* ¹	156.825	156.825	85A	157.275	157.275
03A	156.150	156.150	14	156.700	156.700	24	157.200	161.800	66A	156.325	156.325	77* ¹	156.875	156.875	86	157.325	161.925
--	---	---	15* ²	156.750	156.750	25	157.250	161.850	67* ²	156.375	156.375	78A	156.925	156.925	86A	157.325	157.325
05A	156.250	156.250	16	156.800	156.800	26	157.300	161.900	68	156.425	156.425	79A	156.975	156.975	87	157.375	161.975
06	156.300	156.300	17* ¹	156.850	156.850	27	157.350	161.950	69	156.475	156.475	80A	157.025	157.025	87A	157.375	157.375
07A	156.350	156.350	18A	156.900	156.900	28	157.400	162.000	70 [†]	156.525	156.525	81A	157.075	157.075	88	157.425	162.025
08	156.400	156.400	19A	156.950	156.950	37A* ⁴	157.850	157.850	71	156.575	156.575	82A	157.125	157.125	88A	157.425	157.425
09	156.450	156.450	20	157.000	161.600	61A	156.075	156.075	72	156.625	156.625	83A	157.175	157.175	P4* ⁴	161.425	161.425
10	156.500	156.500	20A	157.000	157.000	--	---	---	73	156.675	156.675	84	157.225	161.825			
11	156.550	156.550	21A	157.050	157.050	63A	156.175	156.175	74	156.725	156.725	84A	157.225	157.225			

[†] DSC operation only.

*¹ Low power only.

*² Momentary high power

*³ UK Marina Channels: M1=37A (157.850 MHz), M2=P4 (161.425 MHz) for U.K. version only

NOTE: Simplex channels, 3, 21, 23, 61, 64, 81, 82 and 83 **CANNOT** be lawfully used by the general public in U.S.A. waters.

SECTION 2 INSIDE VIEWS

• LOGIC BOARD

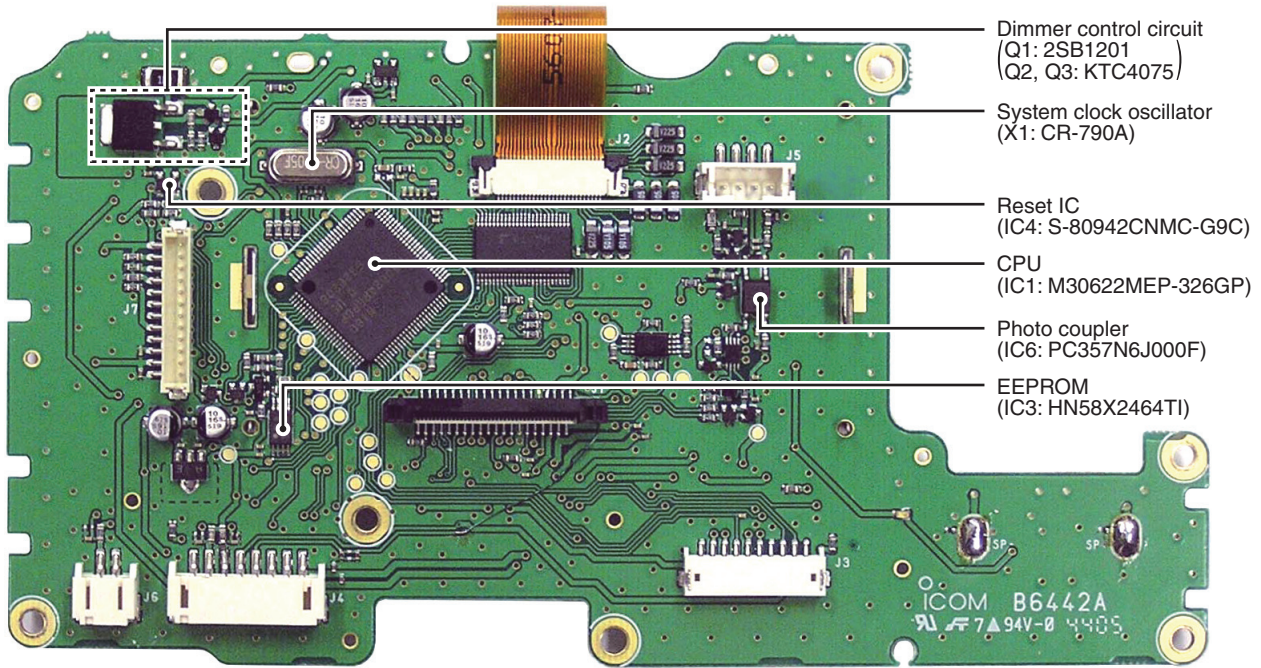

• MAIN UNIT

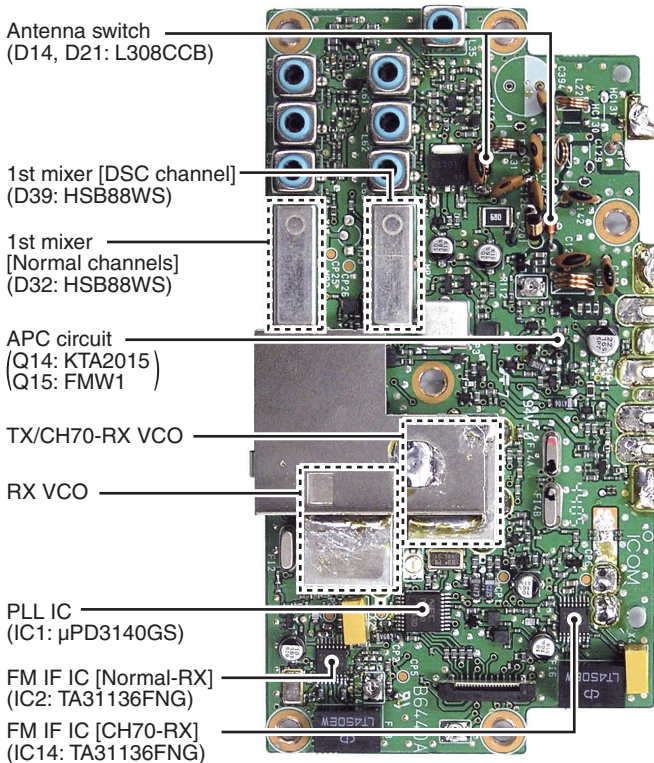

• AF UNIT

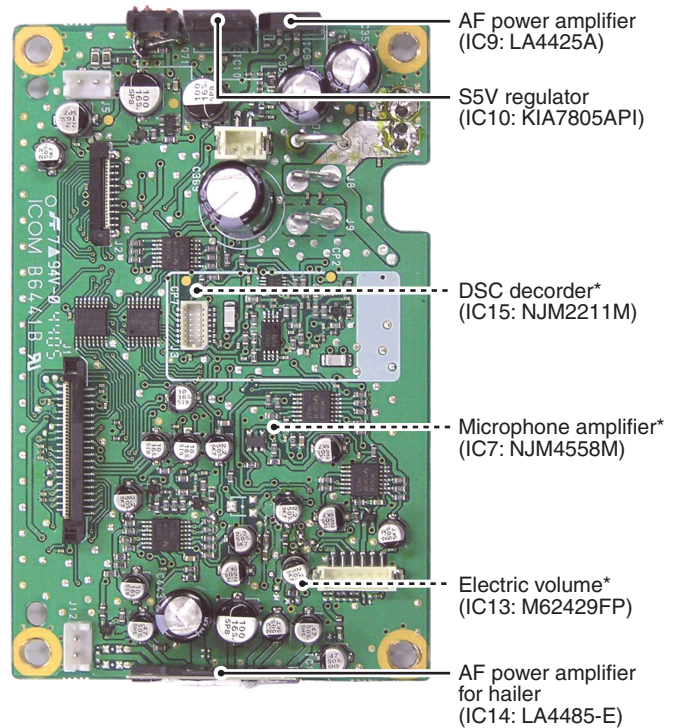

*Located under side of the point

SECTION 3 DISASSEMBLY INSTRUCTIONS

• Opening the transceiver case

- ① Unscrew 6 screws (A).
- ② Disconnect 2 cables from J1 and J5.
- ③ Remove the front unit.
- ④ Unscrew 6 screws (B), and remove the rear panel.

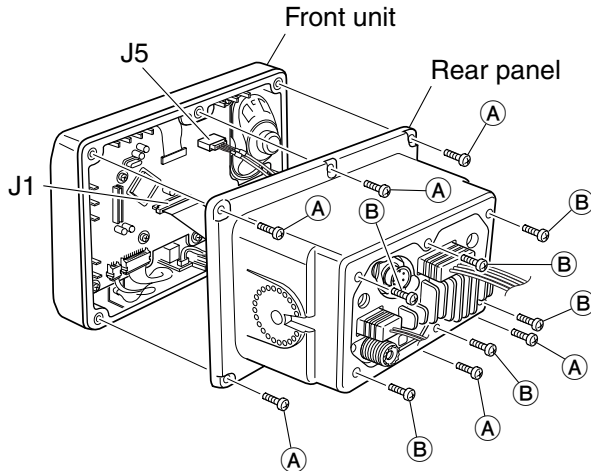

• Removing the LOGIC board

- ① Disconnect 3 connectors from J6, J4 and J3.
- ② Unsolder 2 points (A).
- ③ Unscrew 7 screws (B), and remove the LOGIC board from the front panel.

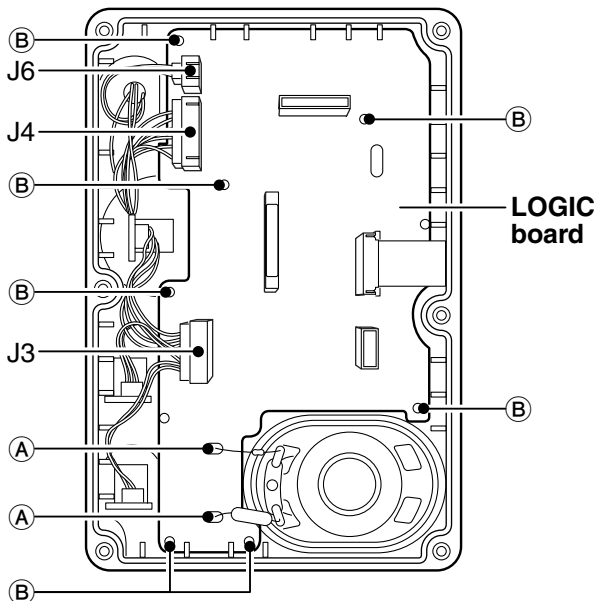

• Removing the MAIN unit

- ① Remove the shield cover.

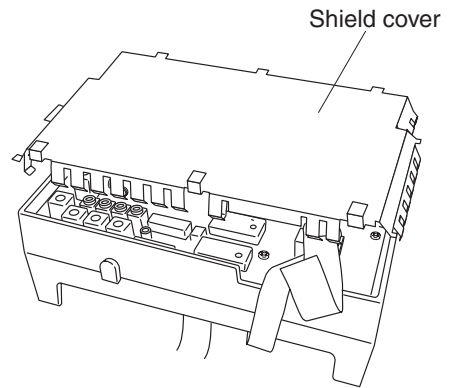

- ② Disconnect the flat cable (A) from J2.
- ③ Unsolder 14 points (B).
- ④ Unscrew 6 screws (C), and remove the MAIN unit from the chassis.

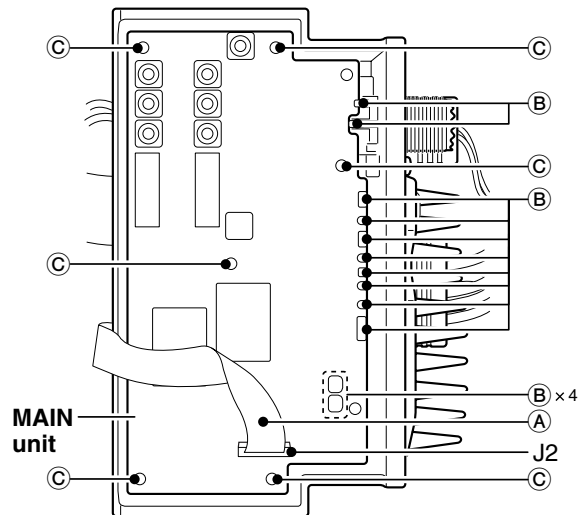

• Removing the AF unit

- ① Disconnect 2 flat cables (A) from J1 and J2.
- ② Disconnect 6 connectors from J5, J6, J8, J9, J11 and J12.
- ③ Remove 2 clips (B).
- ④ Unsolder 4 points (C).
- ⑤ Unscrew 4 screws (D), and remove the AF unit from the chassis.

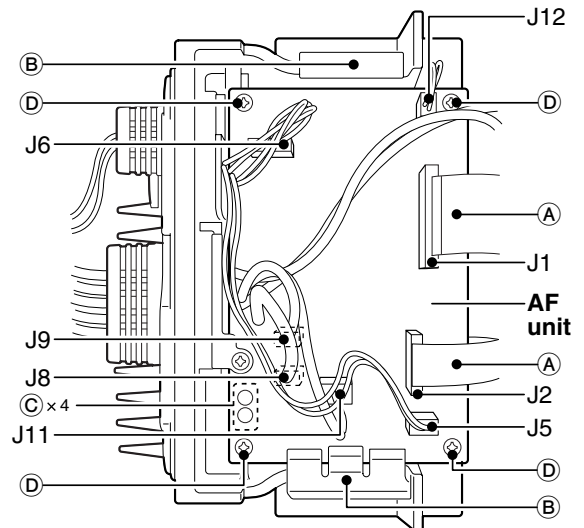

SECTION 4 CIRCUIT DESCRIPTION

4-1 RECEIVER CIRCUIT

4-1-1 ANTENNA SWITCH (MAIN UNIT)

The received signals from the antenna connector are passed through the antenna switch which toggles the receive (RX) line and transmit (TX) line.

The received signals from the antenna connector are passed through the low-pass filter (LPF; L21, L22, C126–C129) and the antenna switch (D14 and D21 are OFF).

While transmitting, voltage on the T5V line is applied to D14 and D21, and these are turned ON. Thus the TX line is connected to the antenna, and RX line is connected to the GND to prevent transmit signal entering.

While receiving, no voltage is applied to D14 and D21, and these are turned OFF. Thus the TX line and the antenna is disconnected to prevent received signals entering, and the RX line is disconnected from the GND, and the received signals are passed through the LPF (L31, C142, C143). The filtered signals are then applied to the RF circuits.

4-1-2 RF CIRCUITS (MAIN UNIT)

The RF circuit amplifies received signals within the frequency coverage. The received signals are filtered at the bandpass filter (BPF) and amplified at the RF amplifier.

The received signals from the antenna switch (D14 and D21 are OFF) are divided into the signals for voice communications and the signals for DSC channel at the divider (L35, C151, C152). The divided signals (voice communications) are applied to the tuned RF amplifier (Q21, D26–D29, L36, L37, C161, C162). The amplified signals are then applied to the double balanced 1st mixer (D32, L40, L41) via a two-staged tunable BPF (D30, D31, L38, L39, C173–C178, C196).

4-1-3 1st IF CIRCUITS (MAIN UNIT)

The received signals are converted into the 1st IF signal, and filtered and amplified in the 1st IF circuits.

The amplified received signals from the RF circuits are applied to the 1st mixer (D32, L40, L41), and converted into the 21.7 MHz 1st IF signal by being mixed with the 1st local oscillator (LO) signals from the VCO (Q72, D51, D52).

The converted 1st IF signal is amplified by the 1st IF amplifier (Q22, Q23), and passed through two 1st IF filters (F11, F12) to filter out adjacent signals. The filtered 1st IF signal is amplified by the 1st IF amplifier (Q24), then applied to the FM IF IC (IC2, pin 16).

4-1-4 2nd IF AND DEMODULATOR CIRCUITS (MAIN UNIT)

The 1st IF signal is converted into the 2nd IF signal and demodulated in the FM IF IC.

The 1st IF signal from the 1st IF circuits is applied to the 450 kHz 2nd IF mixer in the FM IF IC (IC2, pin 16), and converted into the 2nd IF signal by being mixed with the 21.25 MHz 2nd LO signal from the reference oscillator (IC2, pin 1, X3).

The converted 2nd IF signal is output from pin 3, and passed through the 2nd IF filter (F13) to suppress sideband noise. The filtered 2nd IF signal is applied to the limiter amplifier (IC2, pin 5). The amplified 2nd IF signal is then FM-demodulated at the quadrature detector (IC2, pins 10, 11, X2) and output from pin 9. The demodulated AF signals are applied to the AF circuits.

4-1-5 AF AMPLIFIER CIRCUITS (AF UNIT)

The demodulated AF signals from the FM IF IC are amplified and filtered in the AF circuits.

The AF signals from the FM IF IC (MAIN UNIT; IC2, pin 9) are passed through the RX selector (IC26, pins 1, 7), AF mute switch (IC3, pins 10, 11), BPF (Q31, Q32) and another AF mute switch (IC4, pins 8, 9) in sequence.

The AF signals from the AF mute switch (IC4, pins 8, 9) are then applied to the volume control pot (VR UNIT; R1) to be adjusted its signal level (=audio output level). The level-adjusted AF signals are applied to the AF power amplifier (IC9, pin1) via the AF mute switch (Q65). The AF signals are obtained 4.5 W (typ.) of AF output power at the AF power amplifier (IC9), and output from pin 4, then applied to the internal speaker (FRONT UNIT; SP1), HM-126B/G or connected external speaker.

• 2nd IF AND DEMODULATOR CIRCUITS

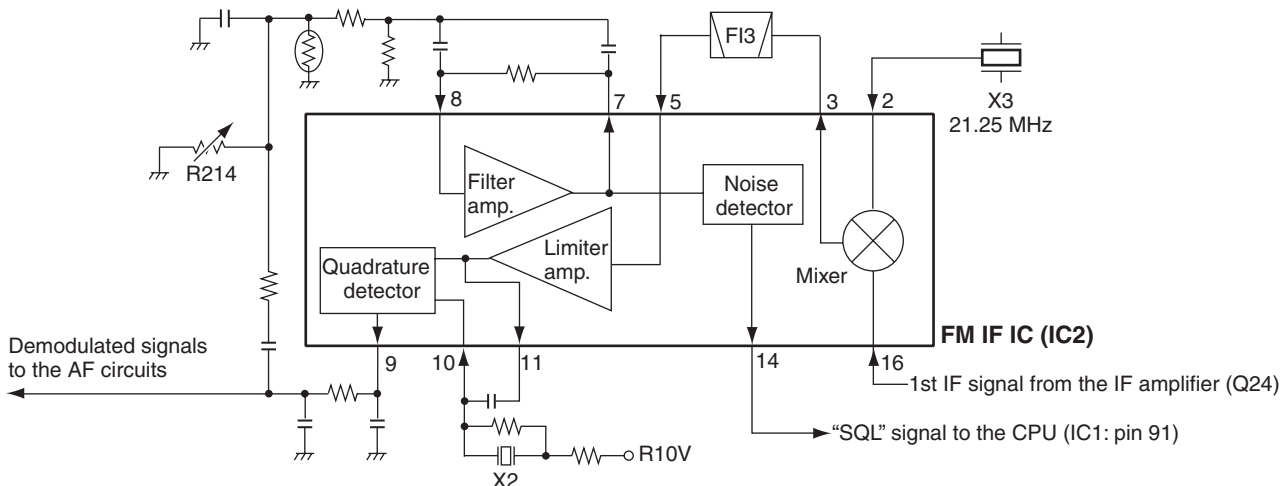

4-1-6 SQUELCH CIRCUITS (MAIN UNIT)

Noise squelch circuit mutes AF output signals when no RF signals are received. By detecting noise components (30 kHz and higher signals) in the demodulated AF signals, the squelch circuit switches the AF mute switch ON and OFF.

A portion of the demodulated AF signals from the FM IF IC (IC2, pin 9) are passed through the squelch threshold adjustment pot (R214) to be adjusted its level. The level adjusted AF signals are passed through the noise filter (IC2, pins 7, 8; R211–R214, R220, C211, C212, C217–C219). The filtered signals are then applied to the noise amplifier section in the IC2 to be amplified the noise components only.

The amplified noise components are converted into the pulse-type signal at the noise detector section, and output from pin 14 as the “SQL” signal. The “SQL” signal is applied to the CPU (LOGIC BOARD; IC1, pin 91), and the CPU outputs “EXSTB,” “EXTOE” signal to the expand IC (AF UNIT; IC27, pins 1, 15) according to the “SQL” signal level. Then the expand IC outputs “RMMUTEM” signal from pin 7 to the AF mute switch (AF UNIT; IC4, pin 6), and outputs “SPMUTE” signal from pin 12 to the AF mute switch (Q65) to cut off the AF line.

4-2 TRANSMITTER CIRCUITS

4-2-1 MICROPHONE AMPLIFIER CIRCUITS (AF UNIT)

The AF signals from the microphone (MIC signals) are filtered and level-adjusted at microphone amplifier circuits.

The MIC signals from the microphone are passed through the MIC mute switch (IC5, pins 10, 11) and the electric volume (IC13, pins 7, 8) which adjusts the MIC signal level (=microphone sensitivity). The level-adjusted MIC signals are then applied to the MIC amplifier (IC7, pin 2). The amplified MIC signals are passed through the MIC line switch (IC3, pins 1, 2) and pre-emphasis circuit (R307, C305) to obtain +3 dB of characteristic. The pre-emphasized signals are then applied to the IDC (Instantaneous Deviation Control; IC8, pins 6, 7) circuit which limits the amplitude of MIC signals to prevent over deviation. The amplitude-limited MIC signals are passed through the LPF (IC8, pins 1, 3) which suppresses 3 kHz and higher audio components.

The filtered MIC signals are passed through the deviation adjustment pot (MAIN UNIT; R327), then applied to the modulation circuit (MAIN UNIT; D2).

4-2-2 MODULATION CIRCUIT (MAIN UNIT)

The modulation circuit modulates the VCO oscillating signal with the AF signals from the microphone.

The MIC signals from the microphone amplifier circuits are applied to the D2 of TX/CH70-RX VCO (Q4, Q5, D1, D3), and modulate the VCO oscillating signal by changing the reactance of D2. The modulated VCO output signal is buffer-amplified by Q6 and Q7, then applied to transmit amplifiers as a transmit signal via the TX/RX switch (D7 is ON, D8 is OFF).

4-2-3 TRANSMIT AMPLIFIERS (MAIN UNIT)

The output signal of TX/CH70-RX VCO is amplified to transmit output power level by the transmit amplifiers.

The transmit signal from the TX/RX switch (D7) is applied to the YGR amplifier (Q10). The amplified transmit signal is applied to the power module (IC3, pin 1) and amplified to the transmit output level. The power-amplified transmit signal is output from pin 4, and passed through the LPF (L19, C121, C124) to filter out the harmonic components. The filtered transmit signal is passed through the antenna switch (D14 and D21 are ON) and another LPF (L21, L22, C126–C129) before being applied to the antenna connector (CHASSIS; J1).

4-2-4 APC CIRCUIT (MAIN UNIT)

The APC (Automatic Power Control) circuit stabilizes transmit output power to prevent transmit output power level change which is caused by load mismatching or heat effect, etc.. The APC circuit also selects transmit output power from high and low power.

A portion of the transmit signal is detected at the power detector circuits (D12, D13), and converted it into DC voltage which is in proportion to the transmit output power level. The detected voltage is applied to the base terminal of differential amplifier (Q15). The divided voltage of the T5V line is applied to another base terminal as the reference voltage.

The differential amplifier compares the detected voltage and reference voltage, and the difference of the voltage controls the bias of the power amplifier module (IC3) via Q14, to reduce/increase the gain of transmit power amplifiers for stable transmit output power.

The change of transmit output power is carried out by the power controller (Q17) using “H/L” signal from the expander (AF UNIT; IC27, pin 4). The transmit power muting is carried out by the TX mute switch (Q16), using the “TMUTE” signal from the expander (AF UNIT; IC27, pin 5).

• APC CIRCUIT

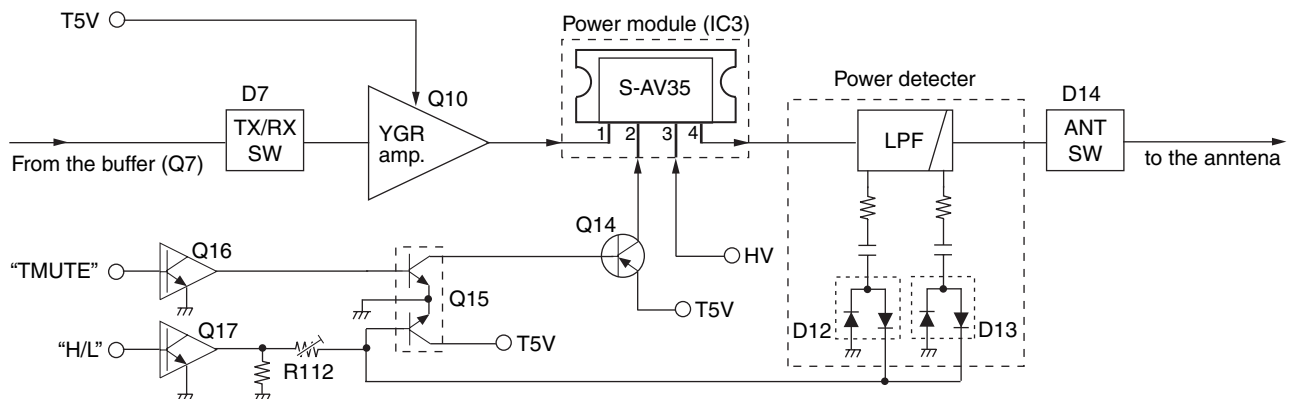

4-3 PLL CIRCUITS

4-3-1 VCO CIRCUITS (MAIN UNIT)

A VCO (Voltage Controlled Oscillator) is an oscillator whose oscillating frequency is controlled by adding voltage (lock voltage).

This transceiver has 2 VCO's; RX VCO (Q72, D51, D52) and TX/CH70-RX VCO (Q4, Q5, D1, D3). The RX VCO oscillates the 1st LO signals for voice communications channels reception, and the TX/CH70-RX VCO oscillates the transmit signal and the 1st LO signals for DSC channel reception.

4-3-1-1 RX VCO

The RX VCO (Q72, D51, D52) output signals are amplified by the buffer amplifiers (Q74, Q76), and applied to the 1st mixer (D32, L40, L41) via the LPF (L12, C78, C79), to be mixed with the received signals to produce the 21.7 MHz 1st IF signal.

A portion of the VCO output is applied to the PLL IC (IC1, pin 2) via the buffer amplifiers (Q74, Q75) and the BPF (L75, C624, C625).

4-3-1-2 TX/CH70-RX VCO

The TX/CH70-RX VCO (Q4, Q5, D1, D3) output signals are amplified by the buffer amplifiers (Q6, Q7),

• While receiving

The buffer-amplified TX/CH70-RX VCO output signals are applied to the 1st mixer (D39, L55, L56) via the TX/RX switch (D7 is OFF, D8 is ON) and the LPF (L65, C535, C537), to be mixed with the received signals to produce the 31.05 MHz 1st IF signal.

• While transmitting

The buffer-amplified TX/CH70-RX VCO output signals are applied to the transmit amplifiers via the TX/RX switch (D7 is ON, D8 is OFF).

A portion of the VCO output is applied to the PLL IC (IC1, pin 19) via the buffer amplifiers (Q3, Q6) and the BPF (L2, C34, C35).

4-3-2 PLL CIRCUIT (MAIN UNIT)

The PLL circuit provides stable oscillation of the transmit and receive 1st LO frequencies. The PLL output frequencies are controlled by the divided ratio (N-data) from the CPU.

• RX VCO LOOP

The RX VCO output signals from the BPF (L75, C624, C625) are applied to the PLL IC (IC1, pin 2). The applied signals are divided at the prescaler and programmable counter according to the "PDATA" signal from the CPU (LOGIC BOARD; IC1, pin 49). The divided signal is phase-compared with the reference frequency signal from the reference frequency oscillator (X1), at the phase detector.

The phase difference is output from pin 8 as a pulse type signal after being passed through the internal charge pump. The output signal is converted into the DC voltage (lock voltage) by passing through the loop filter (R602, R603, R606, C602, C603, C606). The lock voltage is applied to the variable capacitors (D51 and D52 of RX VCO) and locked to keep the VCO frequency constant.

• TX/CH70-RX VCO LOOP

The output signal of TX/CH70-RX VCO from the BPF (L2, C34, C35) are applied to the PLL IC (IC1, pin 2). The applied signals are divided at the prescaler and programmable counter. The divided signal is phase-compared with the reference frequency signal from the reference frequency oscillator (X1), at the phase detector.

The phase difference is output from pin 8 as a pulse type signal. The output signal is converted into the DC voltage (lock voltage) by passing through the loop filter (R7-R9, R41, C4, C5, C43). The lock voltage is applied to the variable capacitors (D53 of TX/CH70-RX VCO) and locked to keep the VCO frequency constant.

If the oscillated signal drifts, its phase changes from that of the reference frequency, causing a lock voltage change to compensate for the drift in the VCO oscillating frequency.

• PLL CIRCUITS

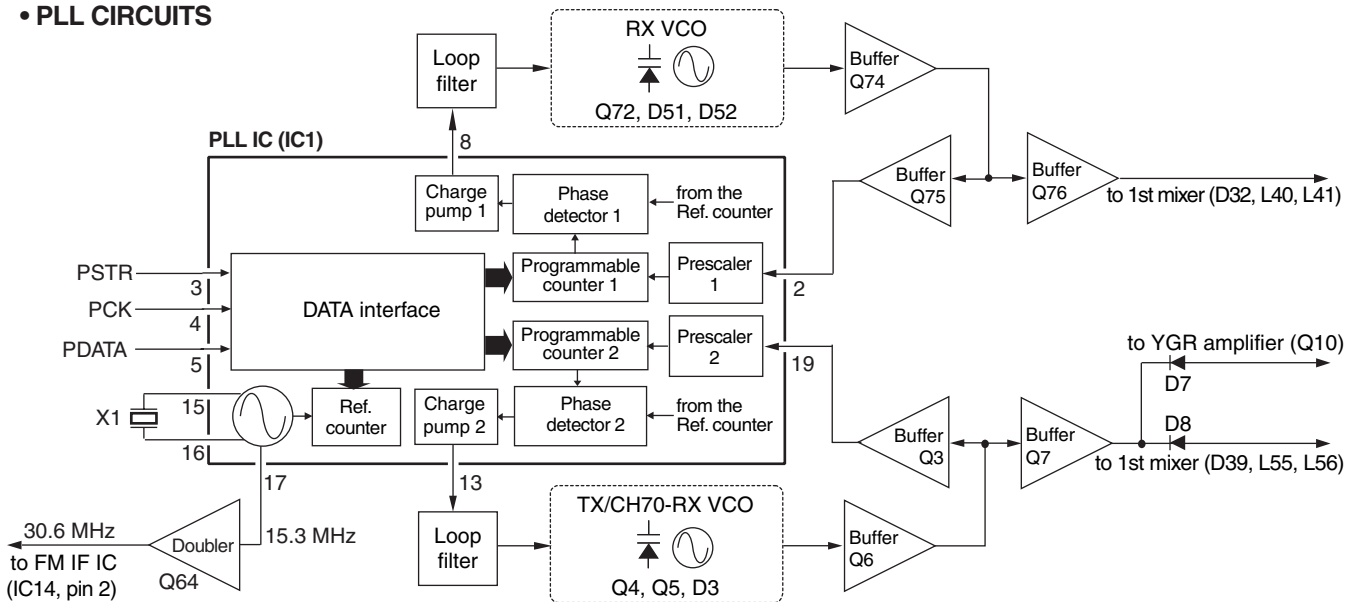

4-4 DSC CRICUITS

The DSC circuits monitors the DSC channel CH70 (156.525 MHz) during stand-by.

4-4-1 RF CIRCUITS (MAIN UNIT)

The divided signals (DSC channel) are from the divider (L35, C151, C152) are applied to the RF amplifier (Q61). The amplified received signals are passed through the BPF (L62, L63, C511, C512, C514–C516) to extract a 156.525 MHz (CH70) signal. The filtered signals are then applied to the double balanced 1st mixer (D39, L55, L56), and converted into the 31.05 MHz 1st IF signal by being mixed with the 1st local oscillator (LO) signals from the VCO (Q4, Q5, D1, D3).

4-4-2 1st IF CIRUIT (MAIN UNIT)

The converted 1st IF signal is applied to the 1st IF amplifier (Q58, Q59), and the amplified 1st IF signal is passed through a pair of crystal filters (F14A, B). The filtered 1st IF signal is amplified by another IF amplifier (Q63), and is then applied to the FM IF IC (IC14, pin 16).

4-4-3 2nd IF AND DEMODULATOR CIRCUITS (MAIN UNIT)

The 1st IF signal from the 1st IF circuits is applied to the 450 kHz 2nd IF mixer in the FM IF IC (IC14, pin 16) and converted into the 2nd IF signal by being mixed with the 30.6 MHz 2nd LO signal from the PLL IC (IC1, pin 17) via the boubler (Q64).

The converted 2nd IF signal is output from pin 3, and passed through the 2nd IF filter (F16) to suppress sideband noise. The filtered 2nd IF signal is applied to the limiter amplifier (IC14, pin 5). The amplified 2nd IF signal is FM-demodulated at the quadrature detector (IC14, pins 10, 11, X4) and output from pin 9. The demodulated signals are applied to the DSC filters (AF UNIT; IC12) and AF circuits.

4-4-4 DSC DECODE (AF UNIT)

The demodulated signals from FM IF IC (MAIN UNIT; IC14, pin 9) are filtered at the LPF (IC12, pins 1, 3) and HPF (IC12, pins 5, 7) to extract the DSC signal. The filtered signals are applied to the DSC decoder IC (IC15, pin 2). The decoded DSC signal is output from pin 7, then applied to the CPU (LOGIC BOARD; IC1, pin 17) to control the transceiver according to the received DSC call content.

4-4-5 DSC ENCODE (LOGIC BOARD)

The DSC signal is generated by the CPU (IC1) and output from pin 1, and applied to the modulation signal line via the buffer amplifier (IC2, pins 5, 7). The DSC signal is filtered at the LPF (AF UNIT; IC8, pins 1, 3), level-adjusted by R327 (MAIN UNIT), then applied to the modulation circuit (MAIN UNIT; D2).

• 2nd IF AND DEMODULATOR CIRCUITS (CH70 RX)

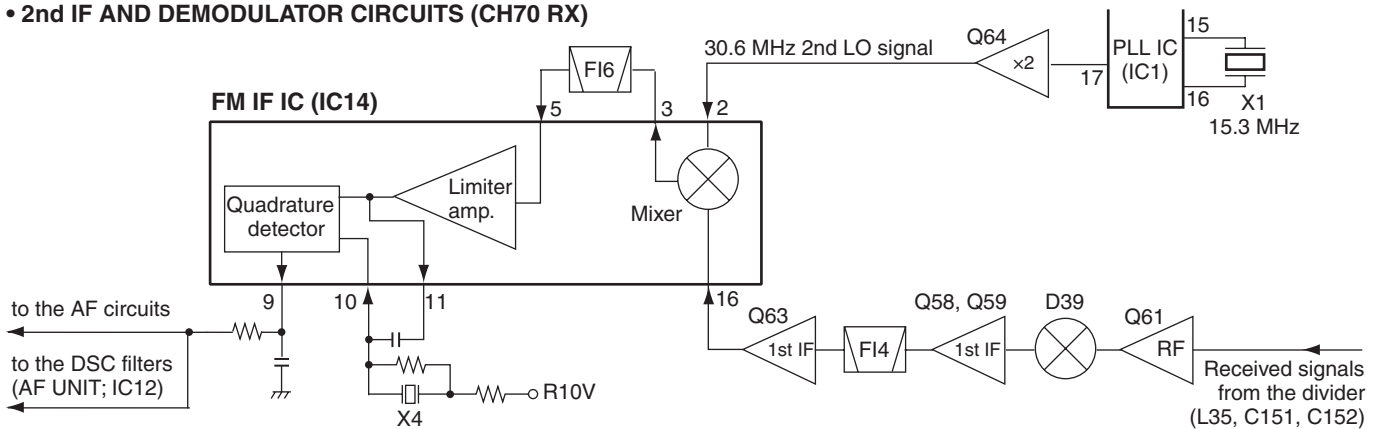

4-5 POWER SUPPLY CIRCUITS (MAIN UNIT)

Voltage from the connected power supply is routed to whole of the circuit in the transceiver via switches and regulators.

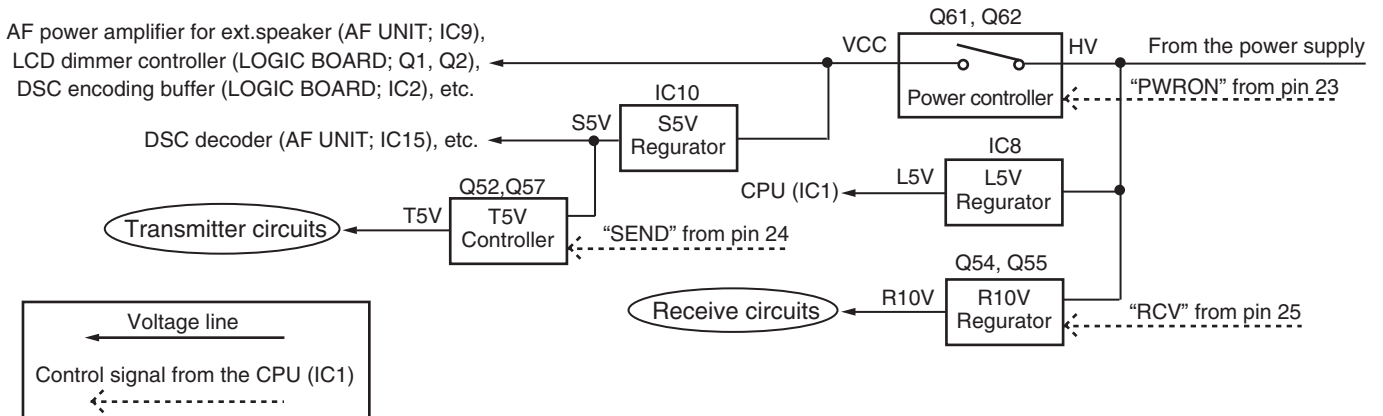

4-6 PORT ALLOCATIONS

4-6-1 CPU (LOGIC UNIT; IC1)

Pin No.	Port Name	Description
1	DSENC	Outputs DSC encode signal to the LPF (AF UNIT; IC8, pin 3).
2	BEEP	Outputs beep sounds to the AF power amplifier (IC9, pin 1).
3	PSTB	Outputs PLL strobe signal to the PLL IC (MAIN UNIT; IC1, pin 3).
4	EXTSTB	Outputs strobe signal to the expand IC's (AF UNIT; IC27/IC28, pin 1).
5	OPSTB	Outputs strobe signal to the attached optional scrambler unit via the option connector (AF UNIT; J3, pin 6).
16	DSDM	Inputs decoded ATIS/DSC signals from the DSC decoder (AF UNIT; IC11, pin 7).
17	DSD70	Inputs decoded DSC signals from the DSC decoder (AF UNIT; IC15, pin 7).
18	PWR	Input port for the [PWR] key. "Low"=When the key is pushed.
21	FOGC	Outputs fog horn signal mute signal to the fog horn mute switch (AF UNIT; IC4).
22	FOG	Outputs fog horn sound to the fog horn mute switch (AF UNIT; IC4).
23	PWRON	Outputs control signal to the power controller (AF UNIT; Q61, Q62).
24	SEND	Outputs T5 line control signal to the T5V controller (MAIN UNIT; Q52, Q57).
25	RCV	Outputs R10V line control signal to the R10V regulator (MAIN UNIT; Q54, Q55).
29-30	NMTXD, NMRXD	Data I/O ports for NMEA data.
35	EDATA	Data I/O port for EEPROM (LOGIC BOARD; IC3, pin 5).
36	ECK	Outputs clock signal to the EEPROM (LOGIC BOARD; IC3, pin 6).
38	EXTOE	Outputs OE signal to the expanders (AF UNIT; IC27/28, pin 15).
40	HANG	Input port for hang up detect signal from HM-126B/G.
41	PTT	Input port for the [PTT] switch of HM-126B/G. "Low"=When the switch is pushed.
42	EVDATA	Outputs serial data to the electric volume IC (AF UNIT; IC13, pin 4)
43	EVCK	Outputs clock signal to the electric volume IC (AF UNIT; IC13, pin 5).
45	DTRS	Input port for the [DISTRESS] key (LOGIC UNIT; S10). "Low"=When the key is pushed.
46	MENU	Input port for the [MENU] key (LOGIC UNIT; S9). "Low"=When the key is pushed.
47	CLR	Input port for the [CLR] key (LOGIC UNIT; S8). "Low"=When the key is pushed.
48	HAIL	Input port for the [HAIL] key (LOGIC UNIT; S7). "Low"=When the key is pushed.
49	LO/DX	Input port for the [IC] key (LOGIC UNIT; S6). "Low"=When the key is pushed.
50	CH16	Input port for the [CH16] key (LOGIC UNIT; S5). "Low"=When the key is pushed.
51	ENT	Input port for the [ENTER] key. "Low"=When the key is pushed.
52	CH/WX	Input port for the [DIAL] key (LOGIC UNIT; S4). "Low"=When the key is pushed.
53	SCAN	Input port for the [SCAN] key (LOGIC UNIT; S3). "Low"=When the key is pushed.
54	H/L	Outputs transmit power select signal to the TX power controller (MAIN UNIT; Q17). "High"=25 W, "Low"=1 W

Pin No.	Port Name	Description
58	UNLK	Input port for PLL unlock signal from the PLL IC (MAIN UNIT; IC1, pin 7). "High"=While the PLL is unlocked.
59	OPTIN	Input port for optional unit attachment detect signal VIA J3 pin 5 (AF UNIT). "Low"=While the optional scrambler unit is attached.
72, 73	DIALA, DIALB	Input port for [DIAL] (DIAL BOARD; DS1).
88	SQLV	Input port for squelch adjustment VR (SQL BOARD; R1).
89	LBAT	Input port for low power supply voltage detect signal.
90	TXDET	Input port for transmit output power level from the power detector (MAIN UNIT; D12, D13).
91	SQL	Input port for noise signal from the FM IF IC (MAIN UNIT; IC2, pin 14).
99	PDATA	Outputs serial data to the PLL IC (MAIN UNIT; IC1, pin 5).
100	PCK	Outputs clock signal to the PLL IC (MAIN UNIT; IC1, pin 4).

4-6-2 EXPAND IC (AF UNIT; IC27)

Pin No.	Port Name	Description
5	TMUTE	Outputs transmit mute signal to the TX mute switch (MAIN UNIT; Q16). "High"=During mute.
6	ATT	Outputs attenuator control signal to the attenuator (MAIN UNIT; D22). "High"=During attenuator ON.
7	RMUTEM	Outputs AF mute signal to the AF mute switch (IC4, pin 6). "Low"=During mute.
11	HAMUTE	Outputs hailer mute signal to the hailer amplifier controller (Q66). "Low"=During mute.
12	SPMUTE	Outputs speaker mute signal to the AF mute switch (Q65). "High"=During mute.
13	RMUTEH	Outputs hailer mute signal to the AF mute switch (Q66). "Low"=During mute.

4-6-3 EXPAND IC (AF UNIT; IC28)

Pin No.	Port Name	Description
4	MMUTEM	Outputs MIC mute signal (for intercom) to AF mute switch (IC5). "Low"=During mute.
6	MMUTEH	Outputs MIC mute signal (for hailer) to AF mute switch (IC5). "Low"=During mute.
7	PTTM	Outputs MIC mute signal (for HM-126B/G) to AF mute switch (IC5). "Low"=During mute.
11	SCON	Outputs the attached scrambler control signal via J3. "High"=When the scrambler is activated.
12	SCUSE	Outputs scrambler by-pass (MIC signals) signal to the AF mute switch (IC4). "High"=When the attached scrambler is activated. "Low"=When the optional scrambler unit is not attached.
13	SCPASS	Outputs scrambler by-pass (demodulated signals) signal to the AF mute switch (IC4). "High"=When the attached scrambler unit is not activated or not attached.

SECTION 5 ADJUSTMENT PROCEDURES

5-1 PREPARATION

■ REQUIRED TEST EQUIPMENTS

EQUIPMENT	GRADE AND RANGE	EQUIPMENT	GRADE AND RANGE
DC power supply	Output voltage : 13.8 V DC Current capacity : More than 7 A	DC voltmeter	Input impedance : 50 kΩ /V DC or better
RF power meter (terminated type)	Measuring range : 0.1–30 W Frequency range : 100–300 MHz Impedance : 50 Ω SWR : Less than 1.2 : 1	Standard signal generator (SSG)	Frequency range : 0.1–300 MHz Output level : 0.1 μV to 32 mV (–127 to –17 dBm)
Frequency counter	Frequency range : 0.1–300 MHz Frequency accuracy: ±1 ppm or better Sensitivity : 100 mV or better	AC millivoltmeter	Measuring range : 10 mV to 10 V
FM deviation meter	Frequency range : 30–300 MHz Measuring range : 0 to ±10 kHz	External speaker	Input impedance : 4 Ω Capacity : More than 5 W
Audio generator	Frequency range : 300–3000 Hz Output level : 1–500 mV	Attenuator	Power attenuation : 40 or 50 dB Capacity : More than 30 W

• CONNECTION

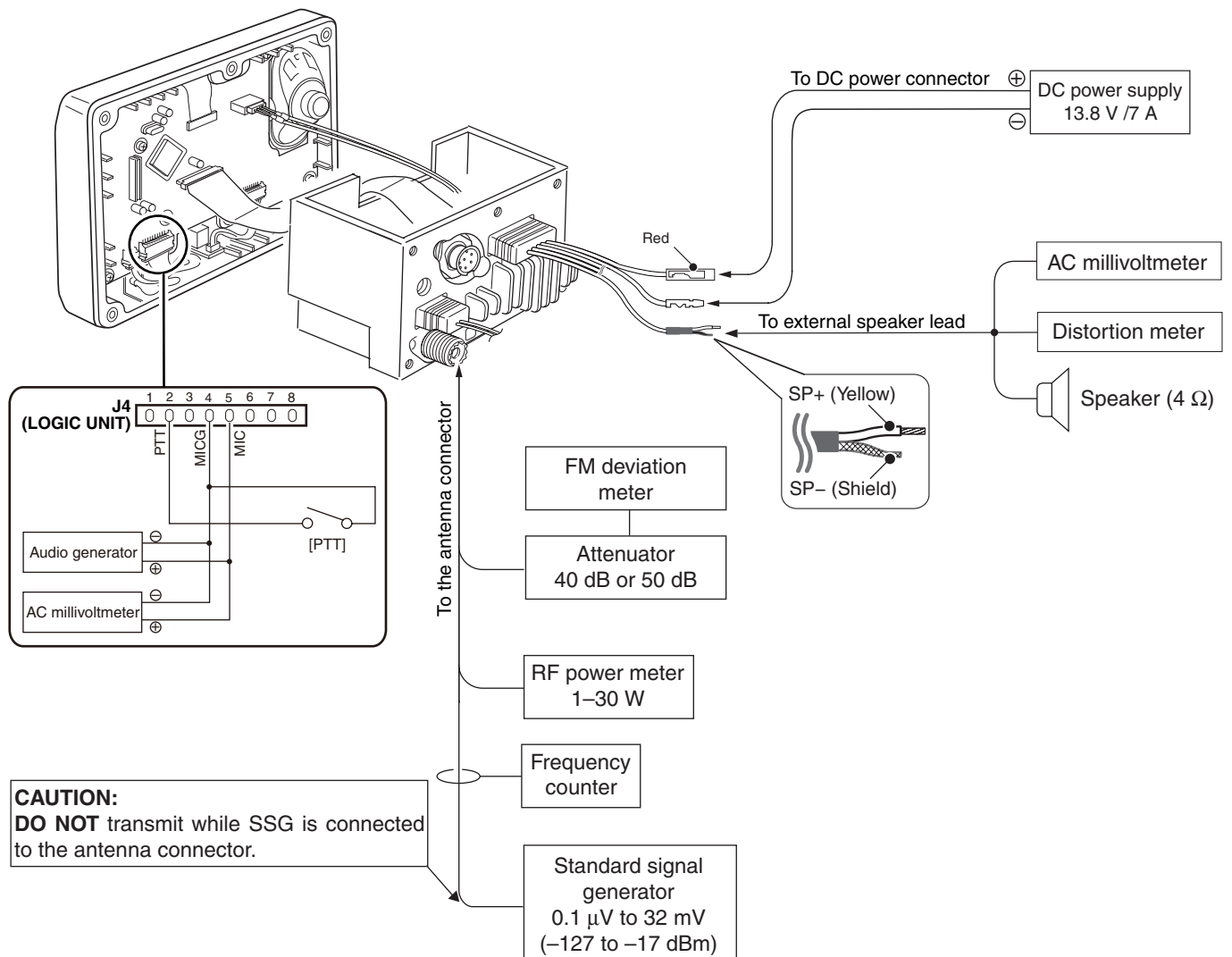

5-2 FREQUENCY ADJUSTMENT

ADJUSTMENT	ADJUSTMENT CONDITION	MEASUREMENT		VALUE	ADJUSTMENT POINT	
		UNIT	LOCATION		UNIT	ADJUST
LOCK VOLTAGE (Regular receive)	1 • Channel : CH16 (156.800 MHz) • Receiving	MAIN	Connect a digital multi-meter or oscilloscope to the check point "CP2".	1.3–2.3 V	MAIN	Verify
	2 • Channel : CH16 (156.800 MHz) • Output power : Low • Transmitting		Connect a digital multi-meter or oscilloscope to the check point "CP1".			Verify
LOCK VOLTAGE (DSC receive)	1 • Receiving	MAIN	Connect a digital multi-meter or oscilloscope to the check point "CP1".	1.3–2.3 V	MAIN	Verify
REFERENCE FREQUENCY	1 • Channel : CH16 (156.800 MHz) • Output power : Low • Connect a power meter to the antenna connector. • Transmitting	Rear Panel	Loosely couple a frequency counter to the antenna connector.	156.800 MHz ±500 Hz	MAIN	C12

• ADJUST AND MEASURE POINTS LOCATION (MAIN UNIT)

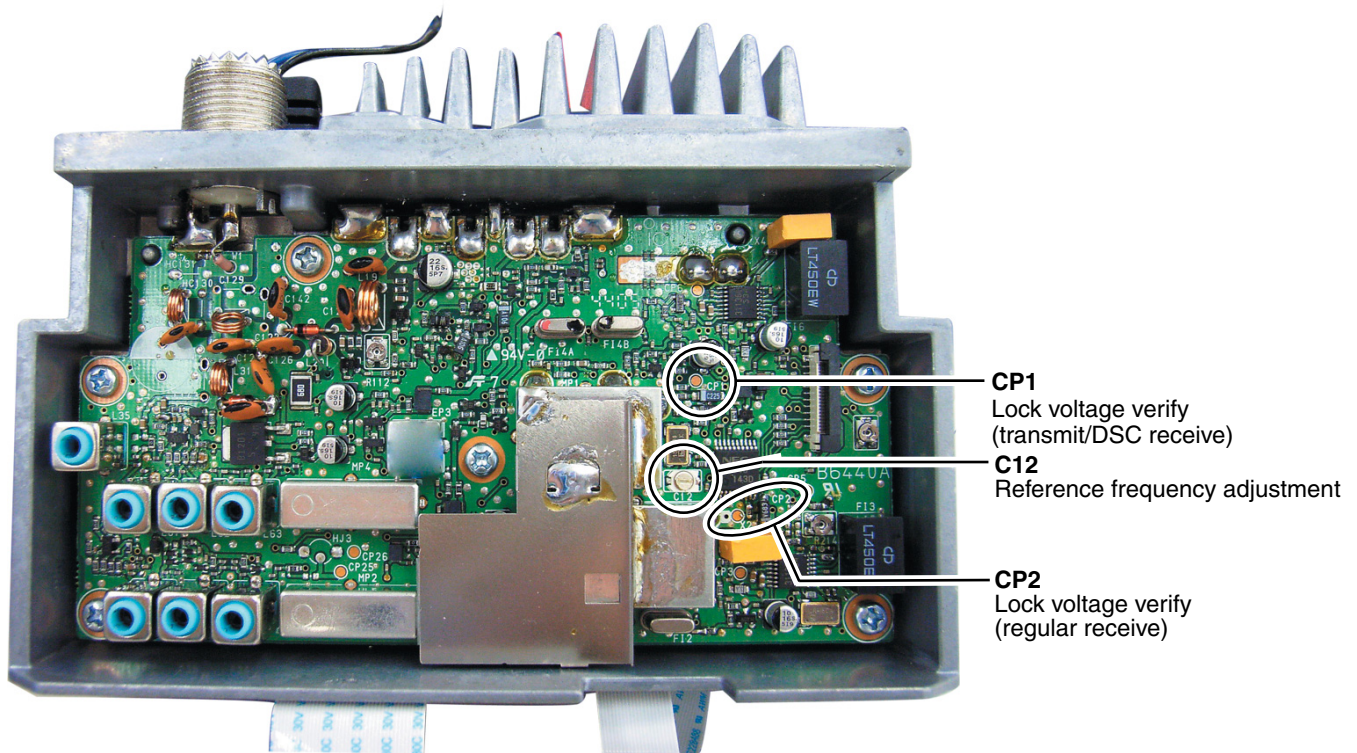

5-3 TRANSMIT ADJUSTMENT

ADJUSTMENT	ADJUSTMENT CONDITION	MEASUREMENT		VALUE	ADJUSTMENT POINT	
		UNIT	LOCATION		UNIT	ADJUST
TRANSMIT OUTPUT POWER	1 <ul style="list-style-type: none"> • Channel : CH16 (156.800 MHz) • Output power : High • Transmitting 	Rear Panel	Connect an RF power meter to the antenna connector.	23–23.5 W	MAIN	R112
DEVIATION	1 <ul style="list-style-type: none"> • Channel : CH16 (156.800 MHz) • Output power : Low • Connect an audio generator to the MIC line (see the page 5-1) and set as; <ul style="list-style-type: none"> Frequency : 1 kHz Level : 30 mV • Set the FM deviation meter as ; <ul style="list-style-type: none"> HPF : OFF LPF : 20 kHz De-emphasis : OFF Detector : (P–P)/2 • Transmitting 	Rear Panel	Connect an FM deviation meter to the antenna connector through an attenuator.	±4.25–4.35 kHz	MAIN	R327

• ADJUST AND MEASURE POINTS LOCATION (MAIN UNIT)

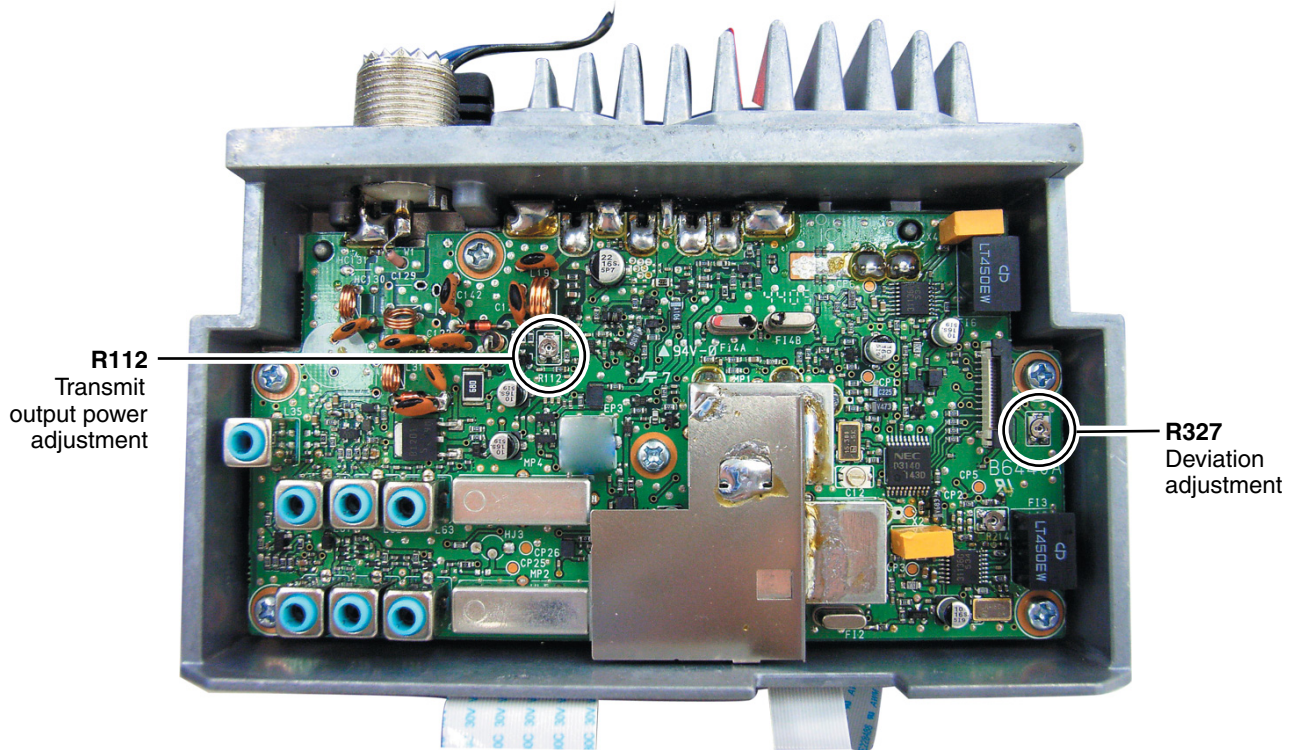

5-4 RECEIVE ADJUSTMENT

ADJUSTMENT	ADJUSTMENT CONDITION	MEASUREMENT		VALUE	ADJUSTMENT POINT	
		UNIT	LOCATION		UNIT	ADJUST
RECEIVE SENSITIVITY (Regular receive)	1 <ul style="list-style-type: none"> • Channel : CH16 (156.800 MHz) • [SQUELCH] : Max. counterclockwise • Set the internal speaker OFF in the SET mode, and connect a distortion meter with a 4 Ω load to [EXT SP] lead receptacle. • Connect an SSG to the antenna connector and set as ; Frequency : 156.800 MHz Level : 0 dBu (-107 dBm) Modulation : 1 kHz Deviation : ±3 kHz • Receiving 	MAIN	Connect a DC volt meter or oscilloscope to the check point "CP3".	Maximum voltage	MAIN	L35 → L36 → L38 → L39 (Repeate two times or more.)
SQUELCH	1 <ul style="list-style-type: none"> • Channel : CH16 (156.800 MHz) • [SQUELCH] : Max. counterclockwise • Connect an SSG to the antenna connector and set as "RECEIVE SENSITIVITY" except the signal level. Level : -4 dBu (-111 dBm) • Receiving 	External speaker	-	Squelch open	MAIN	Turn R214 clockwise to close the squelch. Then turn R214 counter-clockwise to set the point where the squelch opens.
RECEIVE SENSITIVITY (DSC receive)	1 <ul style="list-style-type: none"> • [SQUELCH] : Max. counterclockwise • Connect an SSG to the antenna connector and set as "RECEIVE SENSITIVITY" except the frequency. Frequency : 156.525 MHz (CH70) • Set the internal speaker OFF in the SET mode, and connect a distortion meter with a 4 Ω load to the external speaker lead. • Receiving 	MAIN	Connect a DC volt meter to the check point "CP6".	Maximum voltage	MAIN	L61 → L62 → L63 (Repeate two times or more.)

• ADJUST AND MEASURE POINTS LOCATION (MAIN UNIT)

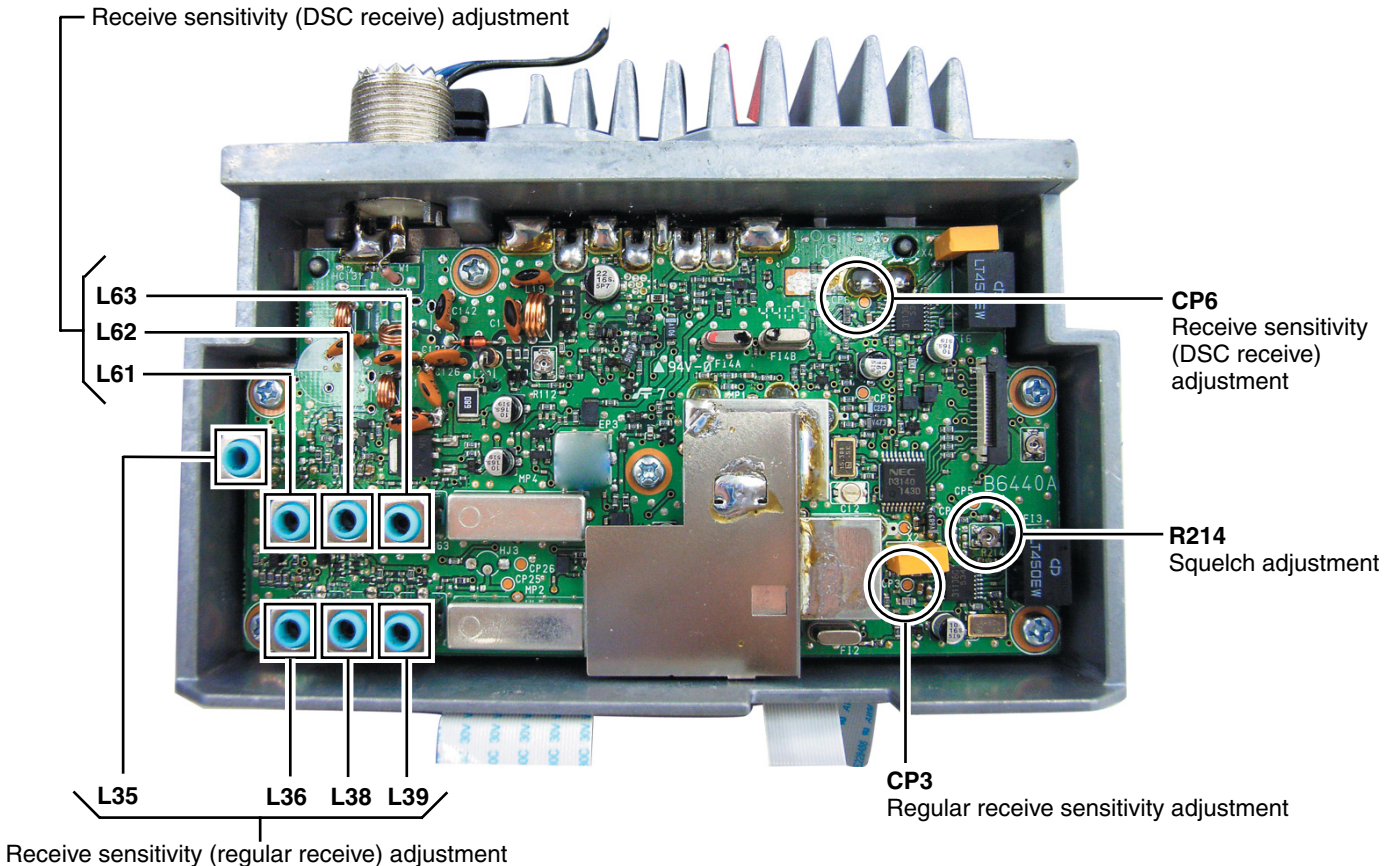

[MAIN UNIT]

Table with columns: REF NO., ORDER NO., DESCRIPTION, M., H/V LOCATION. Contains 54 rows of component data.

[MAIN UNIT]

Table with columns: REF NO., ORDER NO., DESCRIPTION, M., H/V LOCATION. Contains 100 rows of component data.

M.=Mounted side (T: Mounted on the Top side, B: Mounted on the Bottom side) S.=Surface mount

[MAIN UNIT]

REF NO.	ORDER NO.	DESCRIPTION	M.	H/V LOCATION
C134	4030017460	S.CER ECJ0EB1E102K	T	50.6/47.6
C136	4030017460	S.CER ECJ0EB1E102K	T	52.3/46.1
C137	4030017730	S.CER ECJ0EB1E471K	T	54.1/42.8
C138	4030017460	S.CER ECJ0EB1E102K	T	41.9/40.3
C139	4030017460	S.CER ECJ0EB1E102K	T	45/40.9
C140	4030017460	S.CER ECJ0EB1E102K	T	49.2/39.8
C142	4010008080	CER HM60SJ CH 300J 500V		
C143	4010008050	CER HM60SJ CH 180J 500V		
C146	4030017460	S.CER ECJ0EB1E102K	T	20.1/33.1
C150	4030006860	S.CER C1608 JB 1H 102K-T	T	10.5/33.1
C151	4030017640	S.CER ECJ0EC1H150J	T	9.3/27.1
C152	4030017580	S.CER ECJ0EC1H060C	T	9.3/28.1
C153	4030017440	S.CER ECJ0EC1H221J	T	4.3/18.5
C156	4030011600	S.CER C1608 JB 1E 104K-T	T	8.8/11.4
C157	4030016790	S.CER ECJ0EB1C103K	T	8.8/10.3
C158	4030016930	S.CER ECJ0EB1A104K	T	3.1/13.8
C159	4030017460	S.CER ECJ0EB1E102K	T	7.3/16.7
C160	4030016930	S.CER ECJ0EB1A104K	T	7.3/17.7
C161	4030017370	S.CER ECJ0EC1H3R5B	T	16/10.6
C162	4030017600	S.CER ECJ0EC1H080C	T	14.1/10.6
C163	4030017460	S.CER ECJ0EB1E102K	T	19.4/14.1
C164	4030017370	S.CER ECJ0EC1H3R5B	T	10.1/12.6
C165	4030017460	S.CER ECJ0EB1E102K	T	11/11.4
C166	4030017460	S.CER ECJ0EB1E102K	T	20.4/12.9
C173	4030017630	S.CER ECJ0EC1H120J	T	23/12.4
C174	4030017560	S.CER ECJ0EC1H2R5B	T	21.7/10.5
C175	4030017530	S.CER ECJ0EC1H0R5B	T	23/11.5
C176	4030017360	S.CER ECJ0EC1H030B	T	24.8/11.5
C177	4030017370	S.CER ECJ0EC1H3R5B	T	26.1/10.5
C178	4030017600	S.CER ECJ0EC1H080C	T	24.8/12.4
C179	4030016790	S.CER ECJ0EB1C103K	T	28.4/12.8
C180	4030017730	S.CER ECJ0EB1E471K	T	61/19.3
C181	4030017600	S.CER ECJ0EC1H080C	T	31.5/11.5
C184	4030016790	S.CER ECJ0EB1C103K	T	62.1/15.3
C185	4030017660	S.CER ECJ0EC1H330J	T	63.9/9.8
C186	4030017580	S.CER ECJ0EC1H060C	T	63.9/10.8
C187	4030016790	S.CER ECJ0EB1C103K	T	62.1/13.5
C188	4030017460	S.CER ECJ0EB1E102K	T	64.5/13.5
C190	4030017350	S.CER ECJ0EC1H020B	T	44.9/5.6
C191	4030016790	S.CER ECJ0EB1C103K	T	63.6/4.7
C193	4030017550	S.CER ECJ0EC1H1R5B	T	84.4/5
C195	4030017460	S.CER ECJ0EB1E102K	T	94/2.2
C196	4030017340	S.CER ECJ0EC1H010B	T	30.6/10.4
C202	4030016970	S.CER ECJ0EB1C223K	T	97.9/6.2
C203	4030017460	S.CER ECJ0EB1E102K	T	99.2/7
C204	4030016790	S.CER ECJ0EB1C103K	T	103.3/6
C205	4030017430	S.CER ECJ0EC1H101J	T	104.2/12.4
C206	4030017620	S.CER ECJ0EC1H100C	T	114.2/7.8
C207	4030017620	S.CER ECJ0EC1H100C	T	115.2/7.8
C208	4550007520	S.TAN F931A106MAABMA	T	106.5/4.7
C209	4030016790	S.CER ECJ0EB1C103K	T	109.3/7.8
C211	4030017450	S.CER ECJ0EB1E271K	T	112/14.4
C212	4030017450	S.CER ECJ0EB1E271K	T	114.8/14.4
C213	4030017460	S.CER ECJ0EB1E102K	T	114/10.9
C215	4030016930	S.CER ECJ0EB1A104K	T	99.2/9.9
C216	4030016930	S.CER ECJ0EB1A104K	T	110/14.4
C217	4030017400	S.CER ECJ0EC1H220J	T	114.8/21.1
C218	4030016930	S.CER ECJ0EB1A104K	T	107.2/16.6
C219	4030017460	S.CER ECJ0EB1E102K	T	107.2/18.4
C220	4030017460	S.CER ECJ0EB1E102K	T	106.2/14.4
C221	4030011810	S.CER C1608 JB 1A 224K-T	T	102.9/10.5
C222	4030011600	S.CER C1608 JB 1E 104K-T	T	104.1/9.7
C223	4030016930	S.CER ECJ0EB1A104K	T	111.7/26.1
C367	4030017460	S.CER ECJ0EB1E102K	T	67.3/55.4
C368	4030017420	S.CER ECJ0EC1H470J	T	67.3/56.4
C370	4030017430	S.CER ECJ0EC1H101J	T	94/59.9
C371	4030017460	S.CER ECJ0EB1E102K	T	95/59.9
C372	4030016790	S.CER ECJ0EB1C103K	T	96/59.9
C373	4030017400	S.CER ECJ0EC1H220J	T	88/54.4
C374	4030017400	S.CER ECJ0EC1H220J	T	86.9/54.4
C375	4030017430	S.CER ECJ0EC1H101J	T	87/58.6
C376	4030017730	S.CER ECJ0EB1E471K	T	88/58.6
C379	4030017430	S.CER ECJ0EC1H101J	T	80.5/57.9
C380	4030017730	S.CER ECJ0EB1E471K	T	80.5/57
C390	4030016930	S.CER ECJ0EB1A104K	T	34.5/33.2
C391	4030017460	S.CER ECJ0EB1E102K	T	107.7/41.9
C392	4510008540	S.ELE EEE1CA100SR	T	40.2/29.4
C393	4510008540	S.ELE EEE1CA100SR	T	64.9/18.3
C401	4030017460	S.CER ECJ0EB1E102K	T	37.3/35.3
C402	4510008540	S.ELE EEE1CA100SR	T	41.4/37.4
C501	4030011600	S.CER C1608 JB 1E 104K-T	T	20.2/27.7
C502	4030016930	S.CER ECJ0EB1A104K	T	13.4/31.4
C503	4030017440	S.CER ECJ0EC1H221J	T	12.5/27.6
C504	4030017460	S.CER ECJ0EB1E102K	T	19.1/27.9
C505	4030017460	S.CER ECJ0EB1E102K	T	16.2/33.9
C506	4030016930	S.CER ECJ0EB1A104K	T	14.9/33.5
C510	4030017590	S.CER ECJ0EC1H070C	T	10.6/26
C511	4030017370	S.CER ECJ0EC1H3R5B	T	16.6/26
C512	4030017590	S.CER ECJ0EC1H070C	T	21.5/26.1
C514	4030017460	S.CER ECJ0EB1E102K	T	23.2/26
C515	4030017530	S.CER ECJ0EC1H0R5B	T	25/26
C516	4030017600	S.CER ECJ0EC1H080C	T	26.8/26.1
C517	4030017350	S.CER ECJ0EC1H020B	T	29.8/26.1
C520	4030017360	S.CER ECJ0EC1H030B	T	49.7/35.7
C521	4030017460	S.CER ECJ0EB1E102K	T	45.9/36.2

[MAIN UNIT]

REF NO.	ORDER NO.	DESCRIPTION	M.	H/V LOCATION
C522	4030017400	S.CER ECJ0EC1H220J	T	48.8/35.7
C523	4030016970	S.CER ECJ0EB1C223K	T	47.9/36.2
C524	4030017460	S.CER ECJ0EB1E102K	T	46.9/36.2
C527	4030017620	S.CER ECJ0EC1H100C	T	78.3/45.9
C529	4030017460	S.CER ECJ0EB1E102K	T	86.9/49.7
C531	4030016970	S.CER ECJ0EB1C223K	T	91.7/49
C532	4030017460	S.CER ECJ0EB1E102K	T	93/48.2
C533	4030016790	S.CER ECJ0EB1C103K	T	96.4/48.3
C534	4030017460	S.CER ECJ0EB1E102K	T	55.6/24.5
C535	4030017460	S.CER ECJ0EB1E102K	T	55.8/20.5
C537	4030017640	S.CER ECJ0EC1H150J	T	57.1/19.1
C539	4030017460	S.CER ECJ0EB1E102K	T	90.7/46.6
C541	4030017430	S.CER ECJ0EC1H101J	T	97/52.9
C542	4550007520	S.TAN F931A106MAABMA	T	105.8/46.1
C543	4030016790	S.CER ECJ0EB1C103K	T	102.7/48.1
C544	4030017460	S.CER ECJ0EB1E102K	T	101.8/47.2
C546	4030016930	S.CER ECJ0EB1A104K	T	104.2/55.2
C547	4030016930	S.CER ECJ0EB1A104K	T	106/53.3
C548	4030017460	S.CER ECJ0EB1E102K	T	99.9/45.5
C550	4030017460	S.CER ECJ0EB1E102K	T	97.8/47.5
C551	4030011810	S.CER C1608 JB 1A 224K-T	T	95.4/50.8
C552	4030011810	S.CER C1608 JB 1A 224K-T	T	96.7/50.2
C555	4030017350	S.CER ECJ0EC1H020B	T	34.2/26.9
C557	4030017600	S.CER ECJ0EC1H080C	T	31.5/26.7
C558	4030017350	S.CER ECJ0EC1H020B	T	44.9/21.5
C559	4030016790	S.CER ECJ0EB1C103K	T	46.5/27.9
C561	4030016790	S.CER ECJ0EB1C103K	T	100.4/36.3
C562	4030017380	S.CER ECJ0EC1H050B	T	99.4/32.1
C563	4030017390	S.CER ECJ0EC1H180J	T	104/37.1
C564	4030017360	S.CER ECJ0EC1H030B	T	102.3/40.3
C565	4030017390	S.CER ECJ0EC1H180J	T	106.1/40.3
C566	4030017620	S.CER ECJ0EC1H100C	T	103.4/42
C600	4510008540	S.ELE EEE1CA100SR	T	68.1/13.4
C601	4030011810	S.CER C1608 JB 1A 224K-T	T	71.3/13
C602	4550000520	S.TAN TEESVA 1V 683M8R	T	104.6/20.2
C603	4550007390	S.TAN F931C225MAABMA	T	88.9/16.2
C606	4550000520	S.TAN TEESVA 1V 683M8R	T	93.3/10.9
C607	4030017530	S.CER ECJ0EC1H0R5B	T	84.7/14.2
C610	4030017460	S.CER ECJ0EB1E102K	T	83/12.3
C611	4030016930	S.CER ECJ0EB1A104K	T	82.1/12.3
C612	4030017390	S.CER ECJ0EC1H180J	T	84.3/12.9
C613	4030017630	S.CER ECJ0EC1H120J	T	83.8/14.2
C614	4030017390	S.CER ECJ0EC1H180J	T	84.3/12
C615	4030017630	S.CER ECJ0EC1H120J	T	82.9/14.2
C616	4030017540	S.CER ECJ0EC1H1R75B	T	80.8/9.5
C617	4030017460	S.CER ECJ0EB1E102K	T	80.3/17.1
C621	4030017380	S.CER ECJ0EC1H050B	T	80.1/18.8
C622	4030017460	S.CER ECJ0EB1E102K	T	82.8/18
C623	4030017400	S.CER ECJ0EC1H220J	T	86.3/19.7
C624	4030017650	S.CER ECJ0EC1H270J	T	86.8/18.2
C625	4030017650	S.CER ECJ0EC1H270J	T	89/18.2
C626	4030017460	S.CER ECJ0EB1E102K	T	92.4/19.8
C632	4030017460	S.CER ECJ0EB1E102K	T	58.6/17
C633	4030017630	S.CER ECJ0EC1H120J	T	77.2/16.8
C634	4030017620	S.CER ECJ0EC1H100C	T	52.7/14.4
C635	4030017460	S.CER ECJ0EB1E102K	T	53.8/12.1
C641	4030017460	S.CER ECJ0EB1E102K	T	108.7/40.1
C642	4030017730	S.CER ECJ0EB1E471K	T	113.6/46.2
C643	4030017730	S.CER ECJ0EB1E471K	T	116.3/42
C644	4030017730	S.CER ECJ0EB1E471K	T	109/41
C645	4030017730	S.CER ECJ0EB1E471K	T	116/37.4
J1	6510025520	CNR IMSA-6065B-04Z097-PT1		
J2	6510025190	S.CNR IMSA-9639S-20Y905	T	113/37
W1	7120000470	JMP ERDS2T0		
W2	7120000470	JMP ERDS2T0		
EP2	6910002161	CAS CASE-BM7H-LF		
EP3	6910002161	CAS CASE-BM7H-LF		

[AF UNIT]

REF NO.	ORDER NO.	DESCRIPTION	M.	H/V LOCATION
IC3	1130011770	S.IC CD4066BPWR	T	35.5/25.5
IC4	1130011770	S.IC CD4066BPWR	T	78.5/24
IC5	1130011770	S.IC CD4066BPWR	T	59/47
IC6	1130011770	S.IC CD4066BPWR	T	70/54.4
IC7	1110000960	S.IC NJM4558M-TE1	B	63.5/41.6
IC8	1110000960	S.IC NJM4558M-TE1	B	63.5/28
IC9	1110003091	IC LA4485-E		
IC10	1180002780	REG KIA7805API U/P		
IC11	1110003650	S.IC NJM2211M-TE1	[HOL], [FRG]	43/47
IC12	1110006380	S.IC LM2904PWR	T	48.1/40
IC13	1110004490	S.IC M62429FP 700C	B	88.5/44
IC14	1110006111	IC LA4485-E		
IC15	1110003650	S.IC NJM2211M-TE1	B	43/30
IC26	1130013110	S.IC KIC7W53FK-RTK/P	T	40/40.4
IC27	1130011760	S.IC CD4094BPWR	T	46/12.5
IC28	1130011760	S.IC CD4094BPWR	T	46/20.5
IC29	1110002400	S.IC NJM2107F-TE1	T	64.1/37.7

M.=Mounted side (T: Mounted on the Top side, B: Mounted on the Bottom side)
S.=Surface mount

[AF UNIT]

REF NO.	ORDER NO.	DESCRIPTION	M.	H/V LOCATION
C288	4030011600	S.CER C1608 JB 1E 104K-T [HOL], [FRG] only	B	41.7/52.9
C289	4030006900	S.CER C1608 JB 1H 103K-T [HOL], [FRG] only	B	40.3/56.7
C291	4510008540	S.ELE EEE1CA100SR	T	86.3/19.5
C292	4030016790	S.CER ECJ0EB1C103K	T	38.2/37.7
C293	4030017460	S.CER ECJ0EB1E102K	T	39.5/36.6
C301	4030011600	S.CER C1608 JB 1E 104K-T	B	69.1/47.5
C302	4030011600	S.CER C1608 JB 1E 104K-T	T	77.8/39.3
C303	4030011280	S.CER C1608 CH 1H 271J-T	B	70.5/38.5
C304	4030016790	S.CER ECJ0EB1C103K	T	63.8/42.2
C305	4030006900	S.CER C1608 JB 1H 103K-T	B	58.7/19.9
C306	4030007020	S.CER C1608 CH 1H 120J-T	B	64.6/21.5
C307	4030016790	S.CER ECJ0EB1C103K	T	38.1/20.2
C308	4030007130	S.CER C1608 CH 1H 101J-T	B	59.7/41.3
C311	4030017490	S.CER C1608 JB 1A 105K-T	B	69.5/26.4
C312	4030009490	S.CER C1608 JB 1H 821K-T	B	68.9/33.3
C313	4030006880	S.CER C1608 JB 1H 472K-T	B	60.5/33.8
C314	4030007090	S.CER C1608 CH 1H 470J-T	B	63.9/34.9
C315	4030016790	S.CER ECJ0EB1C103K	T	62/25.6
C316	4510008540	S.ELE EEE1CA100SR	T	65/22.5
C317	4030011810	S.CER C1608 JB 1A 224K-T	B	68.9/41.3
C318	4030007090	S.CER C1608 CH 1H 470J-T	B	62.2/47.5
C322	4030017490	S.CER C1608 JB 1A 105K-T	B	60.5/48.8
C323	4030017780	S.CER ECJ0EB1E472K	T	25.2/11.7
C330	4030016790	S.CER ECJ0EB1C103K	T	58.2/26.2
C331	4030016790	S.CER ECJ0EB1C103K	T	18.8/10.2
C332	4030017460	S.CER ECJ0EB1E102K	T	26.7/47.5
C333	4030016790	S.CER ECJ0EB1C103K	T	26.7/45.6
C334	4030017400	S.CER ECJ0EC1H220J	T	68.2/4.9
C335	4030017460	S.CER ECJ0EB1E102K	T	67.3/4.9
C336	4030017460	S.CER ECJ0EB1E102K	T	66.4/4.9
C337	4030017420	S.CER ECJ0EC1H470J	T	69.1/4.9
C338	4030017460	S.CER ECJ0EB1E102K	T	72.3/5.2
C339	4030017420	S.CER ECJ0EC1H470J	T	73.2/5.2
C340	4030017420	S.CER ECJ0EC1H470J	T	63.8/16.4
C341	4030017420	S.CER ECJ0EC1H470J	T	61.3/16.5
C342	4030017460	S.CER ECJ0EB1E102K	T	56.6/14.1
C343	4030017460	S.CER ECJ0EB1E102K	T	55.7/14.1
C344	4030017730	S.CER ECJ0EB1E471K	T	8.9/4.1
C345	4030017730	S.CER ECJ0EB1E471K	T	10.3/37.8
C346	4030017460	S.CER ECJ0EB1E102K	T	28.5/20
C347	4030017680	S.CER ECJ0EC1H820J	T	30.4/19
C348	4030017680	S.CER ECJ0EC1H820J	T	14.4/54.9
C349	4030017460	S.CER ECJ0EB1E102K	T	21.7/56.5
C350	4030016790	S.CER ECJ0EB1C103K	T	45/9.2
C351	4030006900	S.CER C1608 JB 1H 103K-T	B	8.6/30.3
C352	4510008530	S.ELE EEE1HA2R2SR	T	20.6/6.4
C353	4030017490	S.CER C1608 JB 1A 105K-T	B	4.9/38.7
C354	4030017460	S.CER ECJ0EB1E102K	T	2.7/39.8
C355	4510004591	ELE 16 ME 470 HC+TS	T	7.4/39.9
C356	4510004591	ELE 16 ME 470 HC+TS	T	3.5/43
C357	4030016930	S.CER ECJ0EB1A104K	T	14.7/40
C358	4030017420	S.CER ECJ0EC1H470J	T	14/35.8
C361	4030017460	S.CER ECJ0EB1E102K	T	3.5/46.2
C362	4030017420	S.CER ECJ0EC1H470J	T	3.5/44.6
C363	4030017730	S.CER ECJ0EB1E471K	T	6/44.1
C364	4030017730	S.CER ECJ0EB1E471K	T	13.9/53.8
C365	4030016930	S.CER ECJ0EB1A104K	T	17.7/62.7
C369	4510004601	ELE 16 ME 1000 HC+T0	T	49.3/32.3
C370	4030011600	S.CER C1608 JB 1E 104K-T	T	2.4/50.9
C371	4030016790	S.CER ECJ0EB1C103K	T	3.3/50.9
C375	4030016930	S.CER ECJ0EB1A104K	T	2.1/52.7
C377	4030017420	S.CER ECJ0EC1H470J	T	11.2/20.2
C378	4030017460	S.CER ECJ0EB1E102K	T	9.9/24.3
C379	4030017460	S.CER ECJ0EB1E102K	T	9.8/25.4
C381	4510008500	S.ELE EEE1CA101WP	T	5.6/32.6
C382	4030016790	S.CER ECJ0EB1C103K	T	6.7/32.1
C383	4030011600	S.CER C1608 JB 1E 104K-T	T	12.2/30.1
C384	4030011600	S.CER C1608 JB 1E 104K-T	T	7.2/11.1
C385	4030016790	S.CER ECJ0EB1C103K	T	87.7/56.5
C386	4510008500	S.ELE EEE1CA101WP	T	87.7/54.7
C411	4030016790	S.CER ECJ0EB1C103K	T	87.8/52.3
C412	4030016790	S.CER ECJ0EB1C103K	T	87.8/50.3
C413	4030016790	S.CER ECJ0EB1C103K	T	87.8/48.3
C415	4030016790	S.CER ECJ0EB1C103K	T	83.6/43.7
C416	4030016790	S.CER ECJ0EB1C103K	T	88.6/37.2
C417	4030017460	S.CER ECJ0EB1E102K	B	90.5/49.8
C421	4510008530	S.ELE EEE1HA2R2SR	B	89.8/34.1
C423	4030011600	S.CER C1608 JB 1E 104K-T	B	74.7/42.6
C424	4030007090	S.CER C1608 CH 1H 470J-T	B	10.2/41.4
C425	4030007090	S.CER C1608 CH 1H 470J-T	B	17.8/18.3
C426	4510008530	S.ELE EEE1HA2R2SR	T	91.4/35
C431	4030011810	S.CER C1608 JB 1A 224K-T	B	92.4/41
C441	4030017460	S.CER ECJ0EB1E102K	T	92.4/45.8
C443	4510004591	ELE 16 ME 470 HC+TS	T	97.1/49.7
C447	4510008500	S.ELE EEE1CA101WP	T	92.4/20.5
C448	4510008530	S.ELE EEE1HA2R2SR	T	42.1/45.3
C449	4510008560	S.ELE EEE1HAR47SR	T	41.9/42.6
C450	4510008560	S.ELE EEE1HAR47SR	T	41.4/28.3
C453	4510008560	S.ELE EEE1HAR47SR	T	43.5/44.7
C556	4030018900	S.CER ECJ0EB0J474K	T	
C557	4030016930	S.CER ECJ0EB1A104K	T	
C558	4030018900	S.CER ECJ0EB0J474K	T	
C571	4030016930	S.CER ECJ0EB1A104K	T	

[AF UNIT]

REF NO.	ORDER NO.	DESCRIPTION	M.	H/V LOCATION
C572	4030017900	S.CER ECJ0EB1C123K	T	47.6/43.1
C573	4030017040	S.CER ECJ0EB1A333K	T	42.6/40.4
C574	4030017040	S.CER ECJ0EB1A333K	T	43.6/40.4
C575	4030017730	S.CER ECJ0EB1E471K	T	43.6/38.6
C576	4030016790	S.CER ECJ0EB1C103K	T	51.4/42.3
C577	4030016790	S.CER ECJ0EB1C103K	T	43.6/36.7
C578	4030016790	S.CER ECJ0EB1C103K	T	45/36.3
C579	4030016790	S.CER ECJ0EB1C103K	T	51.6/35.9
C581	4030016790	S.CER ECJ0EB1C103K	T	49.6/35
C582	4030011810	S.CER C1608 JB 1A 224K-T	B	45.7/24
C584	4030016930	S.CER ECJ0EB1A104K	T	51.4/27.7
C585	4510008540	S.ELE EEE1CA100SR	T	57.7/26.6
C586	4340000310	S.MLR ECHU 1C 333JX5	T	45.2/33.7
C587	4030006870	S.CER C1608 JB 1H 222K-T	B	35.2/32.9
C588	4030011600	S.CER C1608 JB 1E 104K-T	B	36.8/31
C589	4030006900	S.CER C1608 JB 1H 103K-T	B	41.6/36.6
C591	4510008570	S.ELE EEE1CA220SR	T	15/10
J1	6510025180	S.CNR IMSA-9639S-40D-TB	T	65.5/10
J2	6510025190	S.CNR IMSA-9639S-20Y905	T	26.4/14.5
J3	6510016431	S.CNR 53307-1471	T	46.5/28.5
J5	6510003381	CNR B02B-EH-S (LF) (SN)	T	84.8/53.3
J6	6510021441	S.CNR B6B-ZR-SM4-TF (LF) (SN)	T	
J8	6510025500	CNR OP-12	T	
J9	6510025500	CNR OP-12	T	
J11	6510018961	S.CNR B2B-PH-SM4-TB (LF) (SN)	T	19.5/35.8
J12	6510003381	CNR B02B-EH-S (LF) (SN)	T	
F1	5210001000	S.FUS ERBSE2R50U	T	6.1/9.9
W1	8900015060	CBL OPC-1545 (P0.5,N40,L110) <TJM>	T	
W2	8900015050	CBL OPC-1544 (P0.5,N20,L170) <TJM>	T	
EP279	6910018270	S.BEA MMZ1608Y301CT	T	82.8/21.7
EP297	6910018270	S.BEA MMZ1608Y301CT	B	58.6/35.6
EP343	6910014690	S.BEA MPZ1608S221A-T	T	13.9/38.5
EP344	6910014690	S.BEA MPZ1608S221A-T	T	12.1/37
EP352	6910018270	S.BEA MMZ1608Y301CT	B	3.1/38.7
EP443	6910014640	S.BEA MPZ2012S221A-T	B	96.5/13.7
EP444	6910014640	S.BEA MPZ2012S221A-T	B	94.1/14.6

• HM-126B-3/G

[REPLACEMENT UNITS]

ORDER NO.	UNIT NAME	COLOR
0800005503	HM-126B-3 ACC Except [UK-01], [EUR-01]	BLACK
0800009000	HM-126G ACC [UK-01], [EUR-01]	GRAY

[MAIN UNIT]

REF NO.	ORDER NO.	DESCRIPTION	M.	H/V LOCATION
R1	7010006890	RES R20J (12 k)		
R2	7010006880	RES R20J (6.8 k)		
R3	7010006900	RES R20J (15 k)		
R4	7010006910	RES R20J (33 k)		
R5	7070001110	RES 15 ERG2SJ		
C1	4010008030	CER DD104 B 471K 50V		
C2	4030017280	S.CER C1608 CH 1H 471J-T-A	T	28.5/20
J1	6510022450	CNR S07B-EH-S		
MC1	7700002120	MIC KUC2123-030245		
S1	2260002330	SW SKHHLPO14A		
S2	2260002340	SW SKHHAM024A		
S3	2260002340	SW SKHHAM024A		
S4	2260002340	SW SKHHAM024A		
SP1	2510001080	SP S36G04K-09		
EP2	9029701901	TUBE IRRAX 0.7 (d) L=4 mm		

M.=Mounted side (T: Mounted on the Top side, B: Mounted on the Bottom side)
S.=Surface mount

SECTION 7 MECHANICAL PARTS AND DISASSEMBLY

[CHASSIS PARTS]

REF. NO.	ORDER NO.	DESCRIPTION	QTY.
J1	6510004880	Connector MR-DS-E 01	1
W1	8900015070	Cable OPC-1546	1
W2	8900015080	Cable OPC-1547	1
W3	8900015300	Cable OPC-1616	1
MP1	8210022890	2914 rear panel assembly [Black]	1
	8210022900	(inc. MP2) 2914 rear panel (A) assembly [Gray]	1
MP3	8930058780	2577 sheet	1
MP4	8930069321	2914 rear seal-1	1
MP5	8810010610	Screw PH B0 M3 × 8 SUS S	6
MP11	8930069330	2914 chassis	1
MP12	8930034300	1542 ANT seal	1
MP13	8810010610	Screw PH B0 M3 × 8 SUS S	2
MP15	8510017570	2914 module cover	1
MP16	8810010020	Screw PH BT M2.6 × 8 NI-ZU	2
MP17	8930069280	2914 S-bush plate	1
MP18	8930069270	2914 B-bush plate	1
MP19	8810008660	Screw PH BT M3 × 8 NI-ZU	1
MP20*	6910014760	Plate OG-503040	1
MP21	8810008660	Screw PH BT M3 × 8 NI-ZU	6
MP23	8510017540	2914 Shield cover	1
MP31	8810008660	Screw PH BT M3 × 8 NI-ZU	4
MP32	8930069740	2914 S-IC clip	1
MP33	8930069950	Thermally sheet (BE) TC-80CG-AV	1
MP34	8930069750	2914 B-IC clip	1
MP41	8930069310	2914 front seal	1
MP42	8810010620	Screw PH B0 M3 × 12 SUS S	6
MP44	8820001210	2438 screw	1
MP45	8930052290	O ring (AD)	1
MP46	8930055040	2438 cap	1

[FRONT PARTS]

†Differ from optional HM-126.

REF. NO.	ORDER NO.	DESCRIPTION	QTY.
MC1†	0800005503	Microphone HM-126B-3 [Black]	1
	0800009000	Microphone HM-126G [Gray]	1
MP1	8210022870	2914 front panel assembly [Black]	1
	8210022880	(inc. MP6, MP7, MP8, MP9) 2914 front panel (A) assembly [Gray]	1
MP10	8930051970	2345 A-bush plate	1
MP11	8810010020	Screw PH BT M2.6 × 8 NI-ZU	7
MP12	8930069260	2914 earth spring	1
MP21	8930052280	O ring (AC)	3
MP22	8610011370	Knob N312 (ZK) [Black]	2
	8610011640	Knob N312 (B) [Gray]	2
MP23	8610012960	Knob N347 [Black]	1
	8610012980	Knob N347 (A) [Gray]	1

[MAIN UNIT]

REF. NO.	ORDER NO.	DESCRIPTION	QTY.
J1	6510025520	Connector IMSA-6065B-04Z097-PT1	1
EP2*	6910002161	Case-BM7H-LF	1
EP3*	6910002161	Case-BM7H-LF	1
MP1*	6910018290	2914 A-VCO case	1
MP2*	8510014890	2577 DBM case	1
MP3*	8510017560	2914 VCO case	1
MP4*	8510014890	2577 DBM case	1
MP7	8930053480	2345 plate	1
MP8*	8930070520	2914 S-earth spring	1
MP9*	8510018000	2914 A-VCO cover	1

*: Refer to SECTION 9 BOARD LAYOUTS.

[AF UNIT]

REF. NO.	ORDER NO.	DESCRIPTION	QTY.
W1	8900015060	Cable OPC-1545	1
W2	8900015050	Cable OPC-1544	1
MP1*	8930070530	2914 B-earth spring	1

[LOGIC BOARD]

REF. NO.	ORDER NO.	DESCRIPTION	QTY.
DS1	5030002390	LCD HLM7784-010100	1
MP1	8930058440	2577 LCD holder	1
MP2	8210019060	2577 reflector	1
MP3	8930058910	2577 LCD sheet	1
MP4	8930058900	Rubber sheet (BB)	2

[SQL BOARD]

REF. NO.	ORDER NO.	DESCRIPTION	QTY.
R1	7210003150	Variable resistor TP96N97-15SK-10KB-2685	1

[DIAL BOARD]

REF. NO.	ORDER NO.	DESCRIPTION	QTY.
S1	2250000530	Encoder TP90N1007AE20-20F-2914	1
W1	8900015040	Cable OPC-1543	1

[VR BOARD]

REF. NO.	ORDER NO.	DESCRIPTION	QTY.
R1	7210003150	Variable resistor TP96N97-15SK-10KB-2685	1

[ACCESSORIES]

REF. NO.	ORDER NO.	DESCRIPTION	QTY.
W1	8900009041	Cable OPC-891A	1
W3	8900010760	Cable OPC-1096 except [UK], [UK-01] only	1
MP1	8010018154	2345 mobile bracket-4 ZK [Black]	1
	8010020464	2345 mobile bracket (C)-4 [Gray]	1
MP2	8810001490	Screw PH A M5 × 20 SUS	4
MP3	8850000180	Flat washer M5 SUS	4
MP4	8850000500	Spring washer M5 SUS	4
MP5	8610010561	2040 knob bolt-1 [Black]	2
	8820001271	2040 knob bolt (C)-1 [Gray]	2
MP7	8950005110	2289 mic hanger	1
MP8	8810004700	Screw PH A M3 × 16 SUS	2

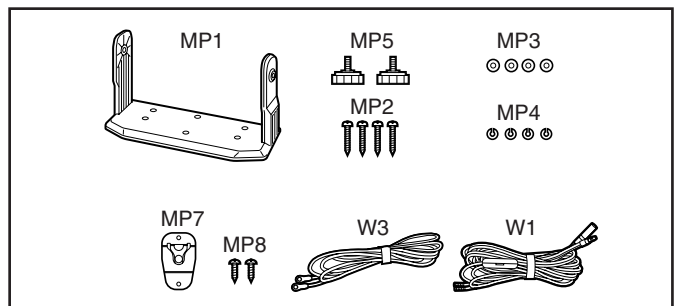

Screw abbreviations

A, B0, BT: Self-tapping
 PH: Pan head ZK: Black
 NI-ZU: Nickel-Zinc
 SUS: Stainless

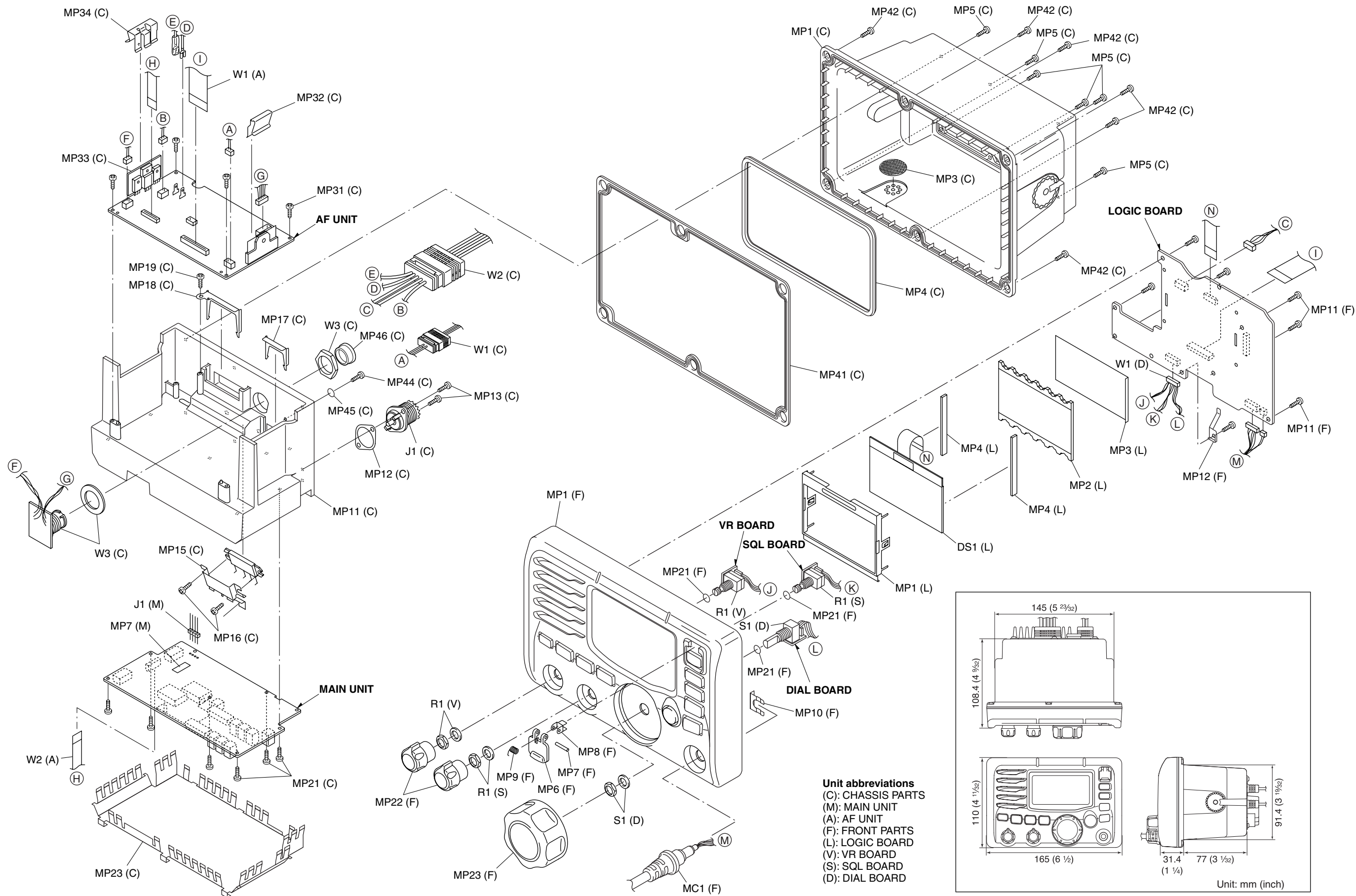

SECTION 8 SEMICONDUCTOR INFORMATION

• HM-126B-3/G

[CHASSIS PARTS]

REF. NO.	ORDER NO.	DESCRIPTION	QTY.
W1	8900014820	Cable OPC-948 [Gray]	1
	8900013590	Cable OPC-949 [Black]	1
MP1	8210022750	2352 front panel-1 [Gray]	1
	8210021410	2352 front panel (A)-1 [Black]	1
MP2	8210020380	2352 rear panel [Gray]	1
	8210020120	2352 rear panel (A) [Black]	1
MP3	8930052160	2352 key	1
MP4	8930052150	2352 PTT rubber	1
MP5	8930052140	2352 PTT holder	1
MP6	8930052690	2352 MIC rubber	1
MP7	8930052120	2352 rubber	1
MP8	8930052110	2352 main seal	1
MP9	8610010870	2352 hanger knob	1
MP10	8310048760	2352 R-plate	1
MP11	8310048780	2352 mic plate	1
MP12	8820001150	2352 screw	5
MP13	8850001850	ICOM washer (Y)	5
MP14	8930052340	O ring (AE)	5
MP15	8930052350	O ring (AF)	1
MP16	8930053870	2352 sheet (A)	1
MP17	8930053040	2352 SP net	1
MP18	8850001610	Spring washer M4 SUS	1
MP19	8810009260	Screw PH BT 2 × 6 NI	3
MP20	8810008900	Screw PH M3 × 6 NI	1
MP21	8810009240	Screw BiH M4 × 10 ZK	1
MP24	8930061010	2715 mic sheet	1

[MAIN UNIT]

REF. NO.	ORDER NO.	DESCRIPTION	QTY.
MC1	7700002120	Microphone KUC2123-030245	1
SP1	2510001080	Speaker S36G04K-9	1

Screw abbreviations

BT: Self-tapping
 PH: Pan head
 ZK: Black
 NI: Nickel

BiH: Binding head
 SUS: Stainless

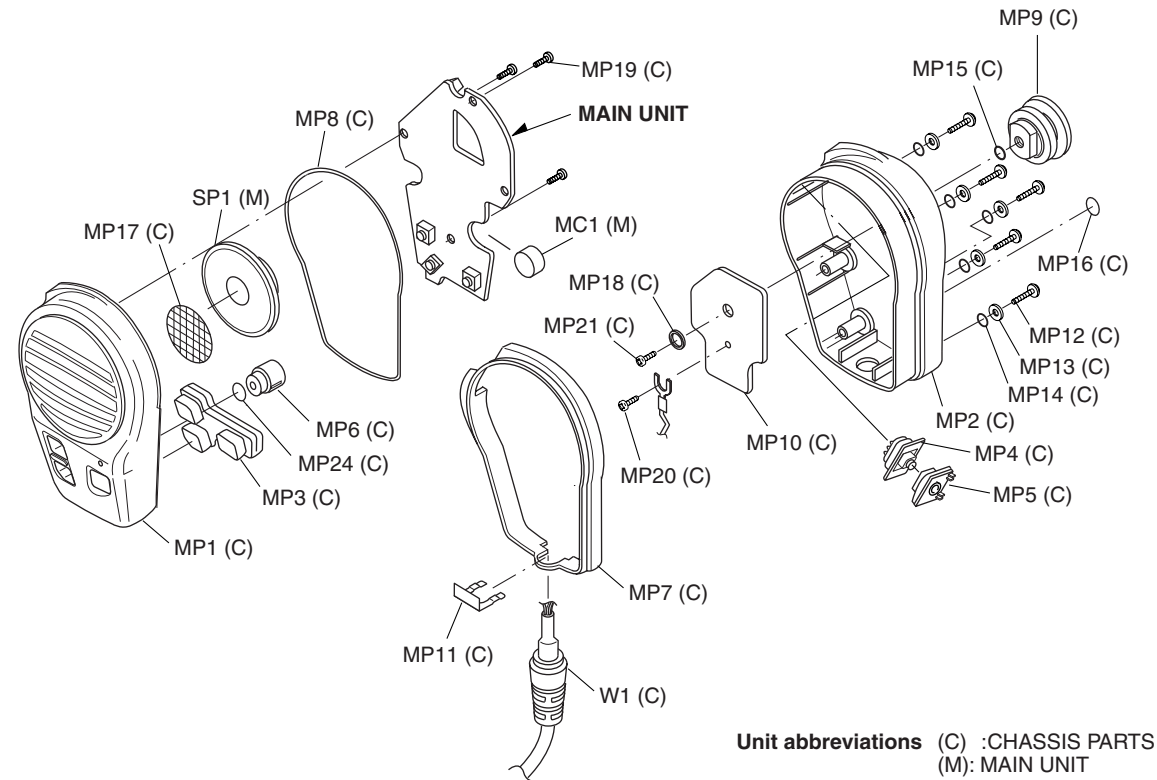

• TRANSISTORS AND FET'S

2SA1576A T106 R (Symbol: FR) 	2SB1143 S (Symbol: B1143) 	2SB1201 S (Symbol: B1201) 	2SC4081 T106 S (Symbol: BS) 	2SC4226 T1 R25 (Symbol: R25)
2SK1069 4 TL (Symbol: FJ) 	3SK292 (Symbol: UK) 	FMW1 T148 (Symbol: W1) 	KRA304 (Symbol: PD) KTA2015Y (Symbol: ZY) 	KRC402 (Symbol: NB) DTC144TU (Symbol: TU)
KRC404 (Symbol: ND) KTC2875-B (Symbol: MB) KTC3880S (Symbol: HG) 	KTC4075 BL (Symbol: LBL) KTC4080 (Symbol: HH) 	PMBFJ310 (Symbol: M10) 	TPC6104 (Symbol: S3D) 	XP6501 AB (Symbol: 5N)

• DIODES

1SS372 (Symbol: N9) 	AVR-M1005C080MTABB 	DSA3A1 (Color: Green) 	HSB88WSTR (Symbol: Silver line) 	HSM88ASR TR (Symbol: C3)
HVC350B (Symbol: B0) 	HVC358B (Symbol: B2) 	KDS122 (Symbol: C3) 	KDS4148U (Symbol: UH) 	KDV214E (Symbol: UO)
L308CCB (Symbol: CC) 	MA77 (Symbol: 4B) 	MA8036 L (Symbol: 3_6) 	MA8062 M (Symbol: 6-2) 	

SECTION 9 BOARD LAYOUTS

9-1 AF UNIT

• TOP VIEW

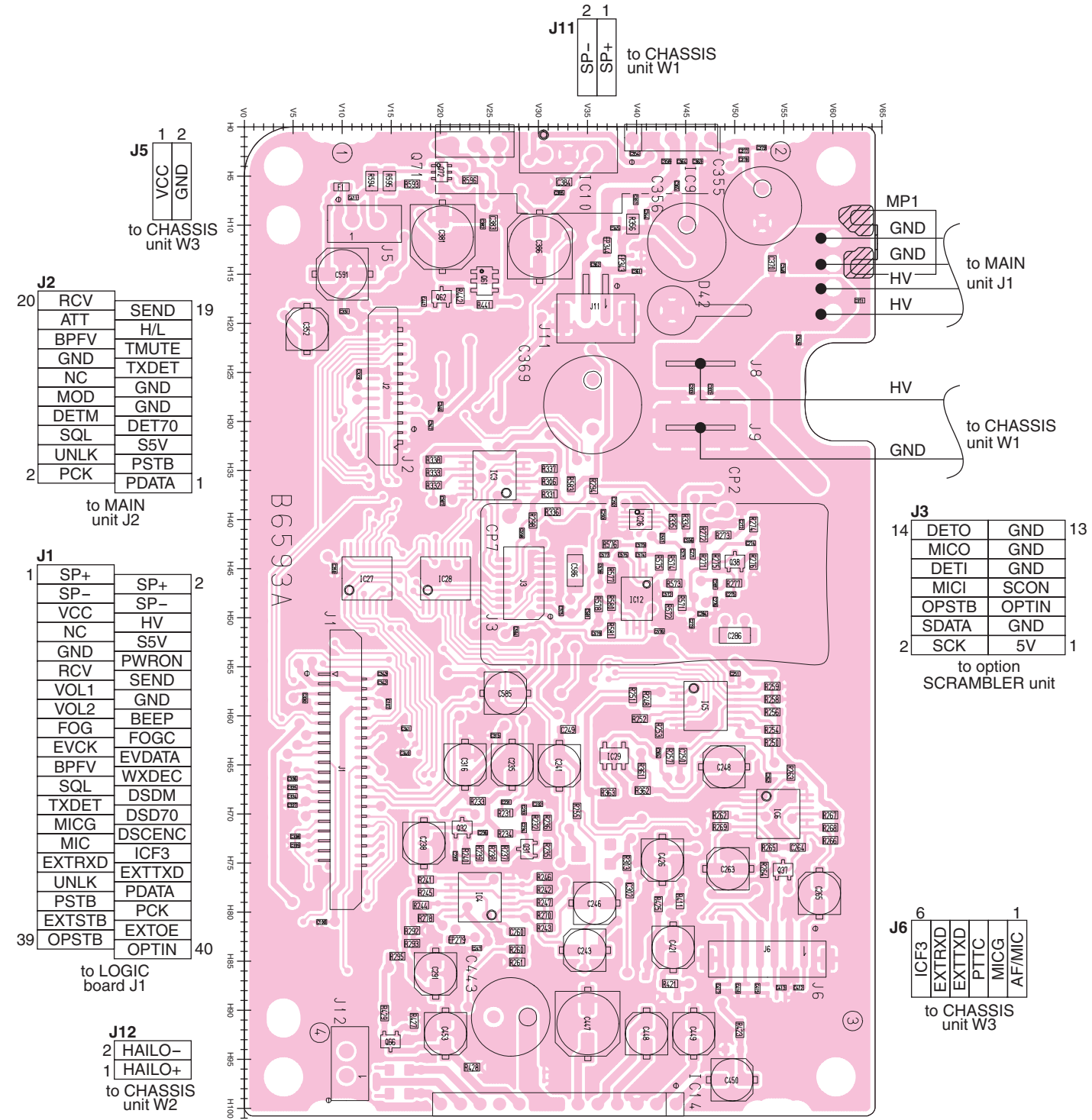

9-2 MAIN UNIT

• TOP VIEW

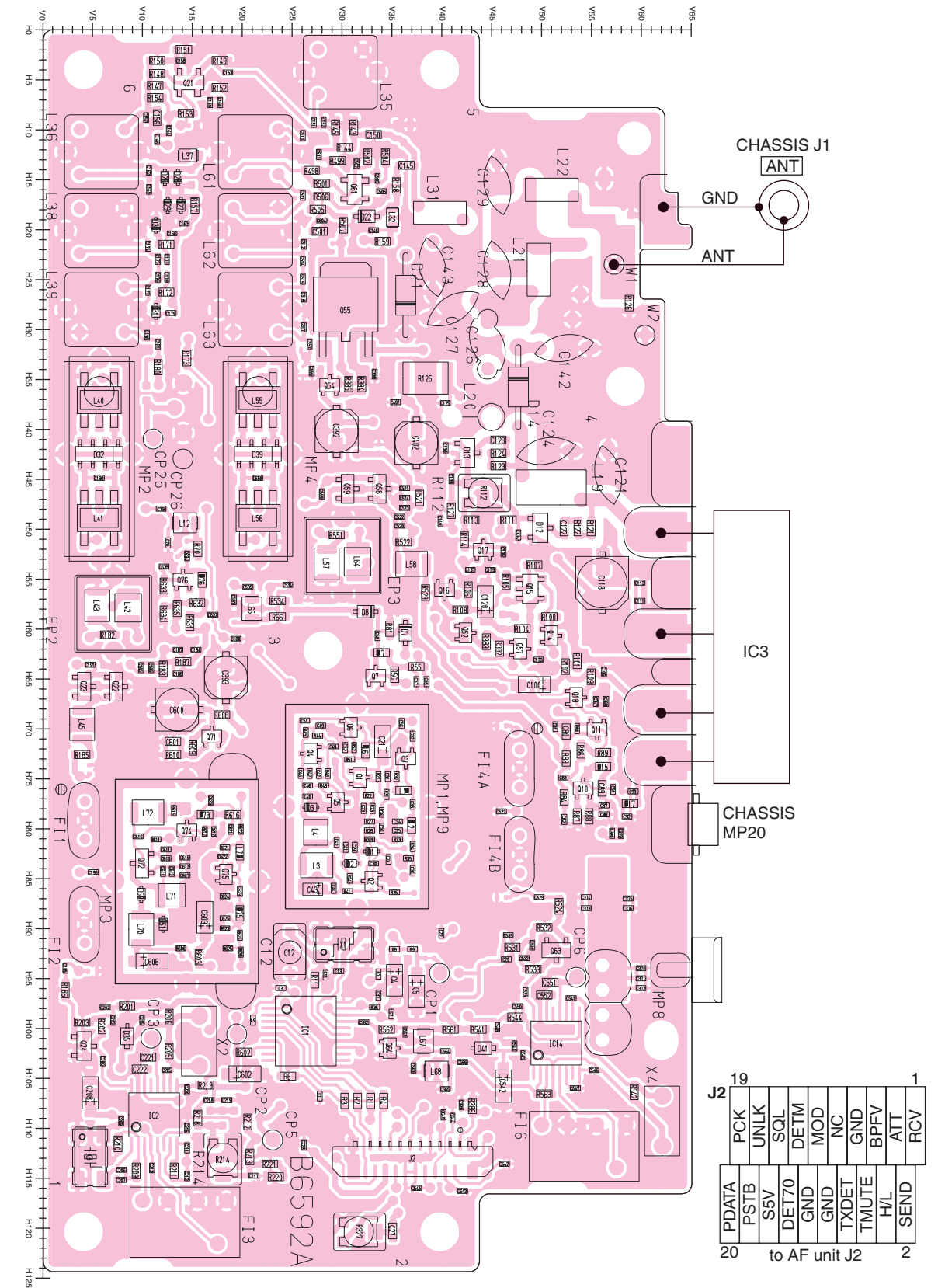

• BOTTOM VIEW (MAIN UNIT)

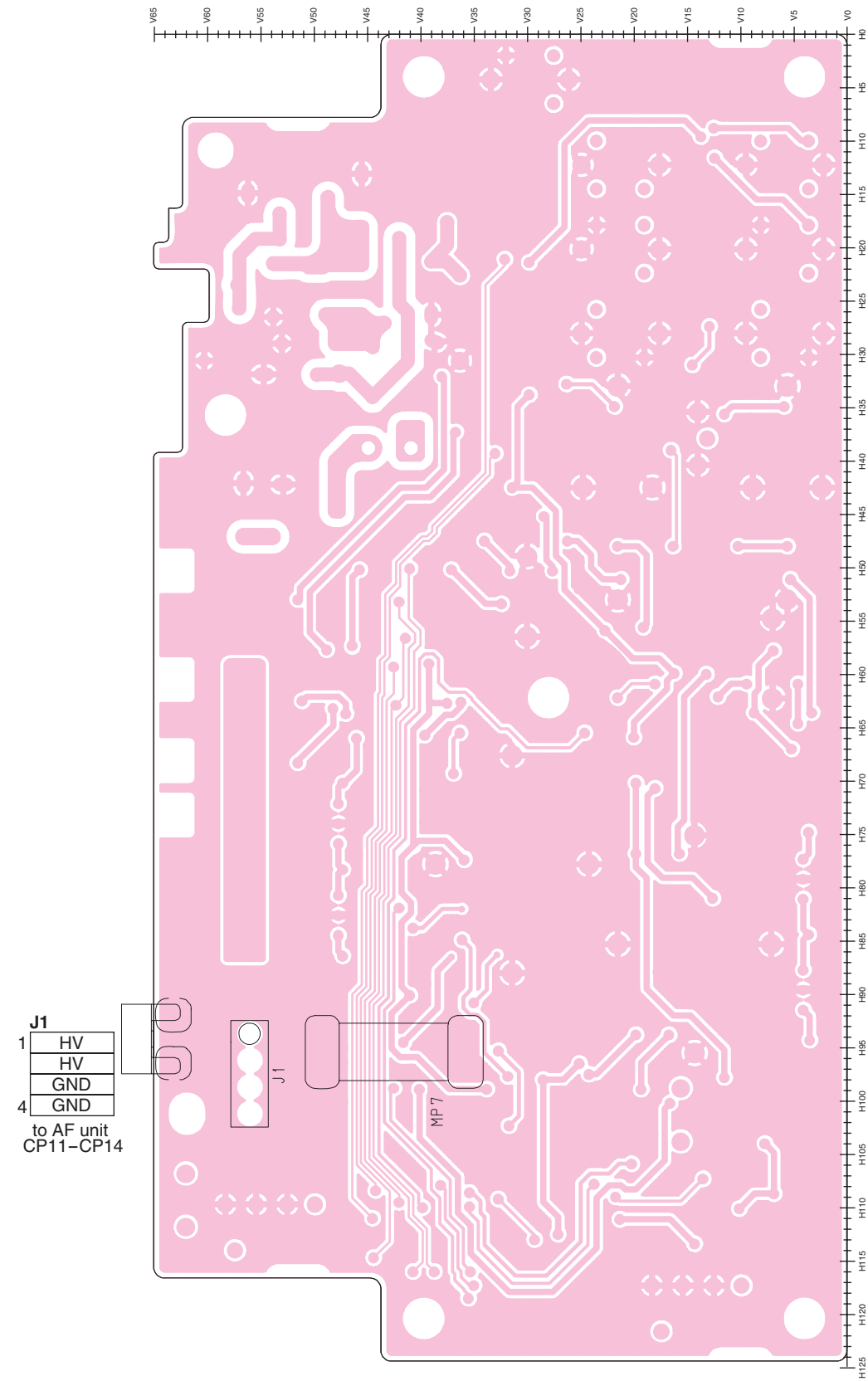

• BOTTOM VIEW (AF UNIT)

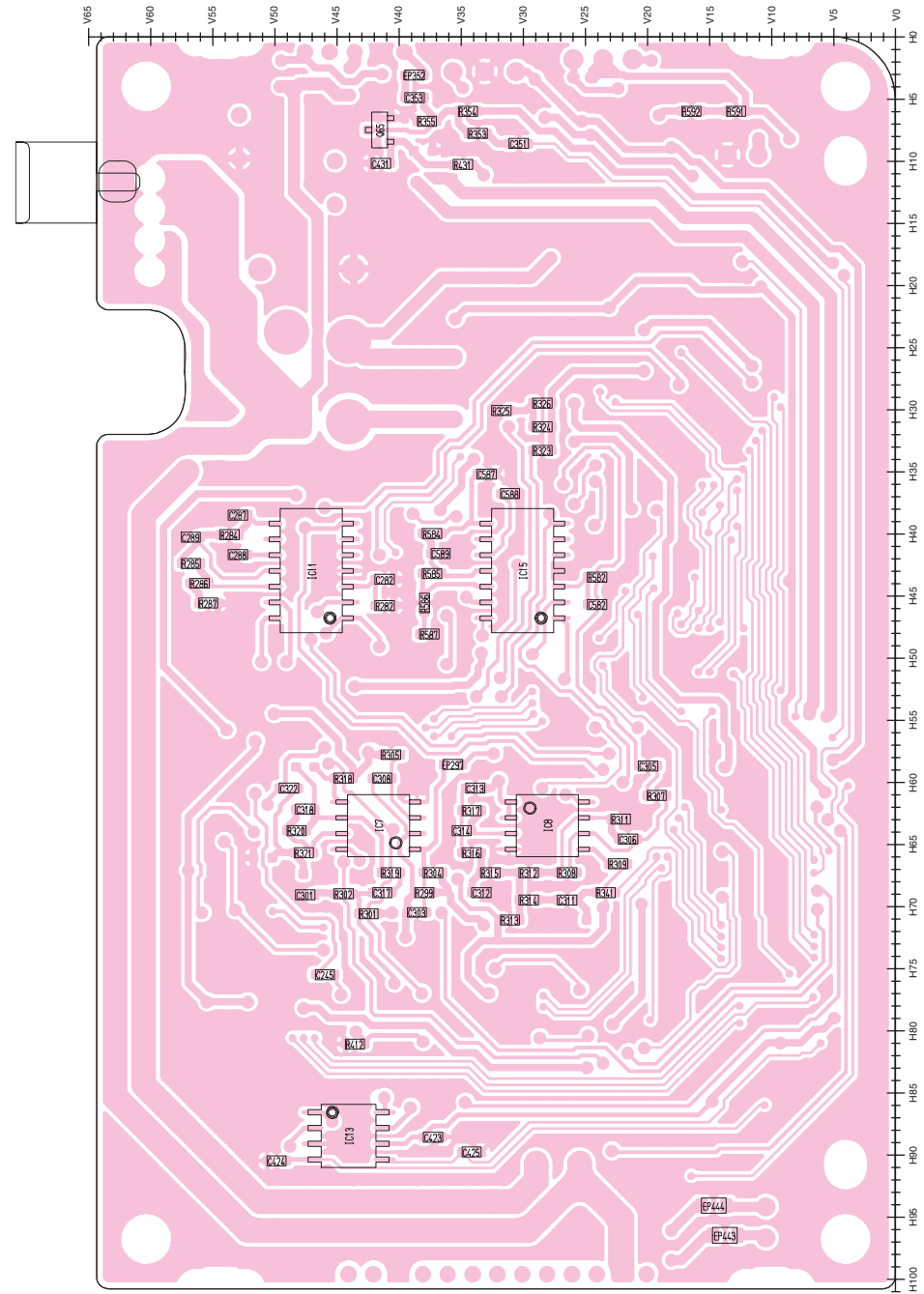

9-3 HM-126B-3/G
• TOP VIEW

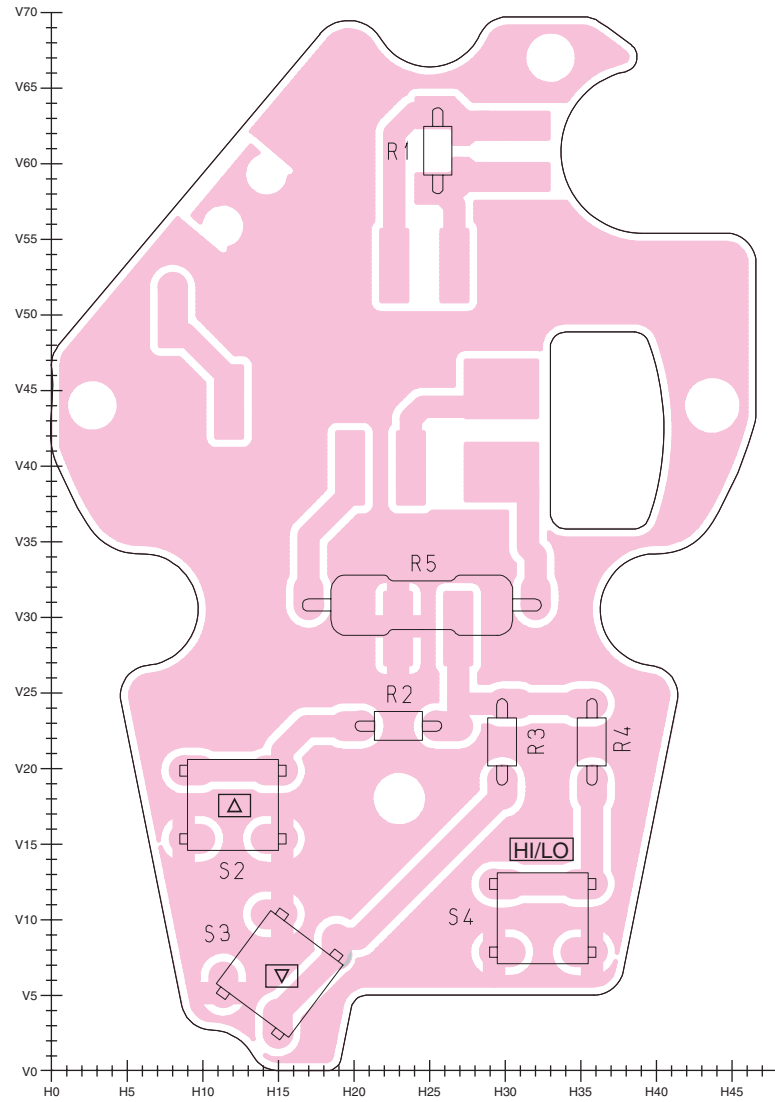

9-4 VR BOARD
• TOP VIEW

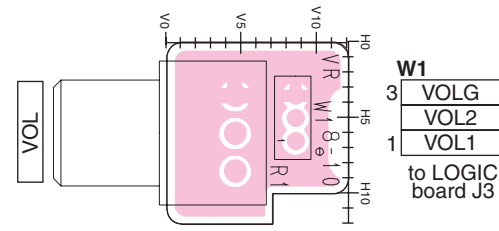

9-5 SQL BOARD
• TOP VIEW

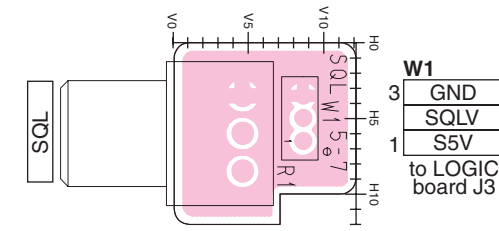

9-6 DIAL BOARD
• TOP VIEW

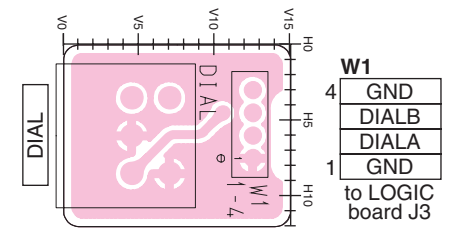

9-7 LOGIC BOARD
• TOP VIEW

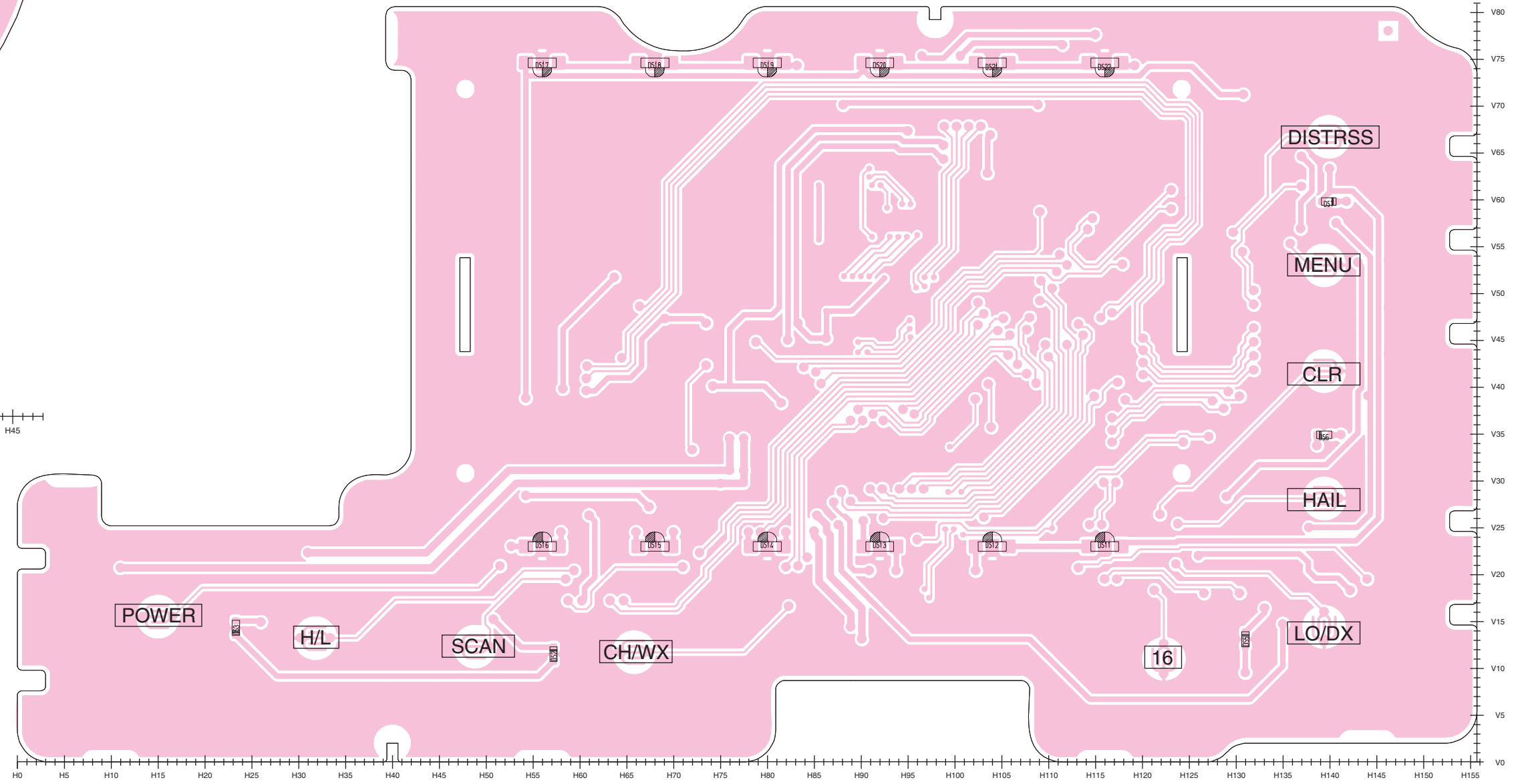

• BOTTOM VIEW (DIAL BOARD)

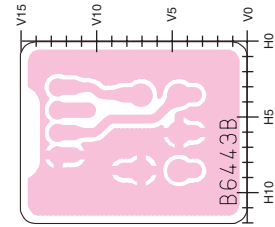

• BOTTOM VIEW (SQL BOARD)

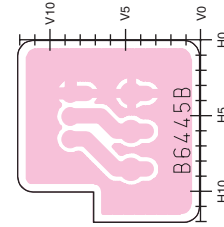

• BOTTOM VIEW (VR BOARD)

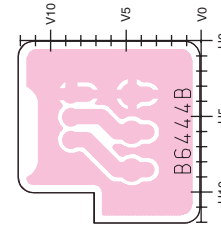

• BOTTOM VIEW (HM-126)

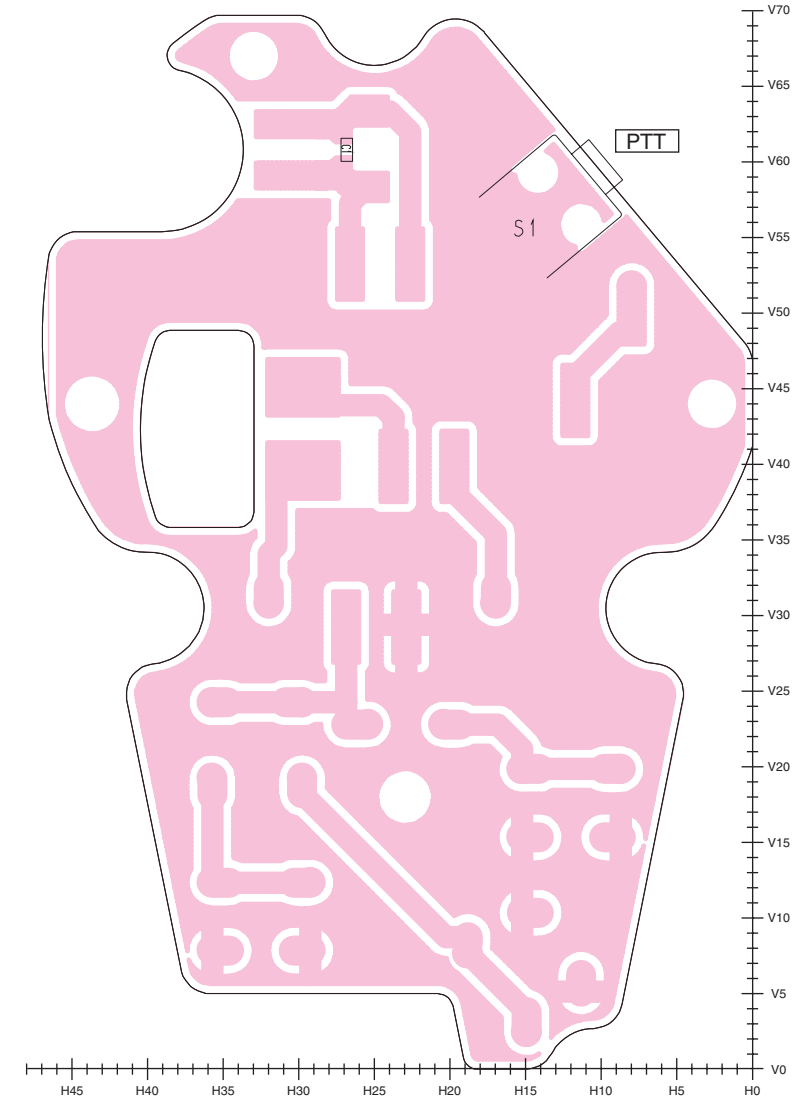

• BOTTOM VIEW (LOGIC BOARD)

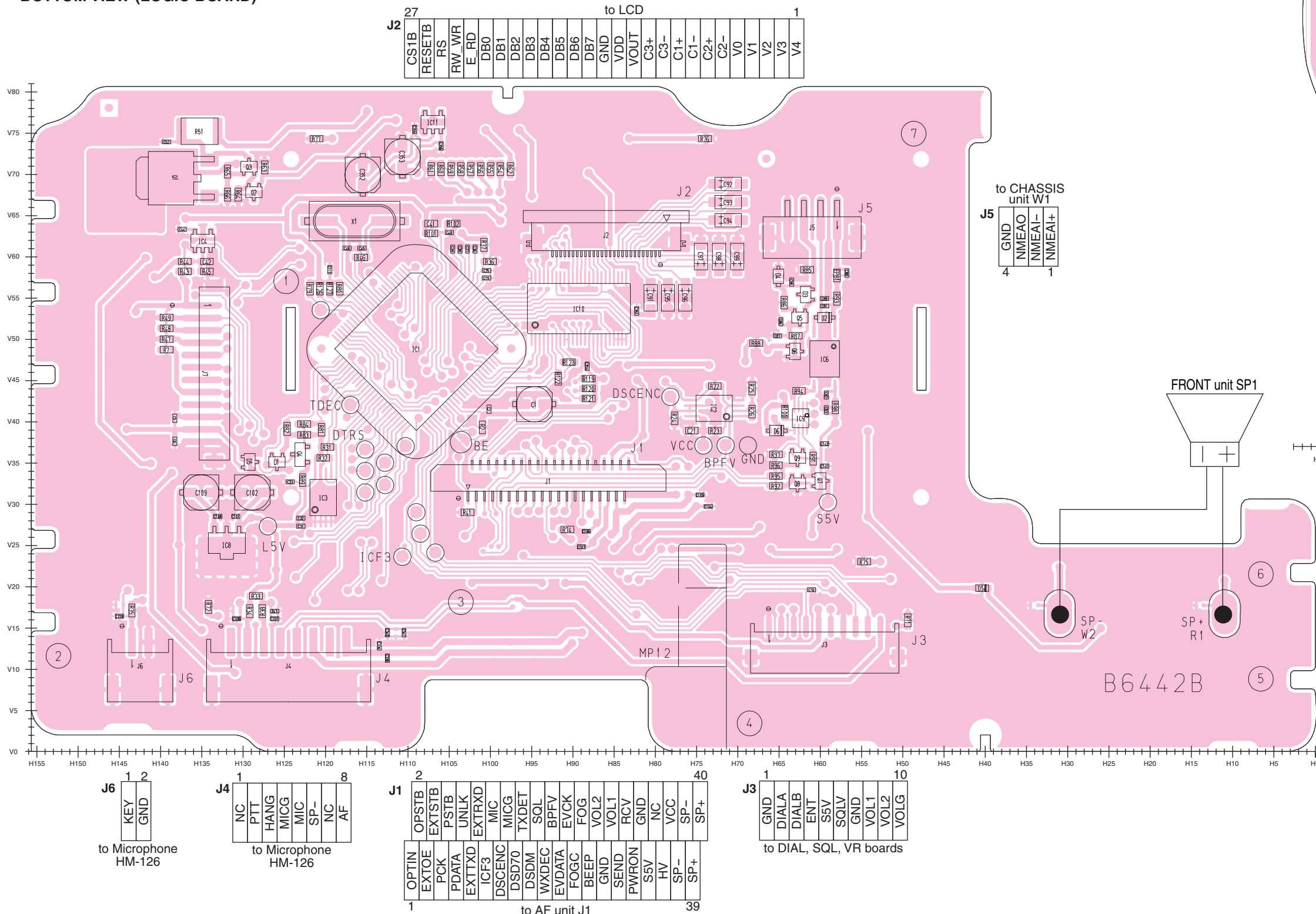

SECTION 10 BLOCK DIAGRAM

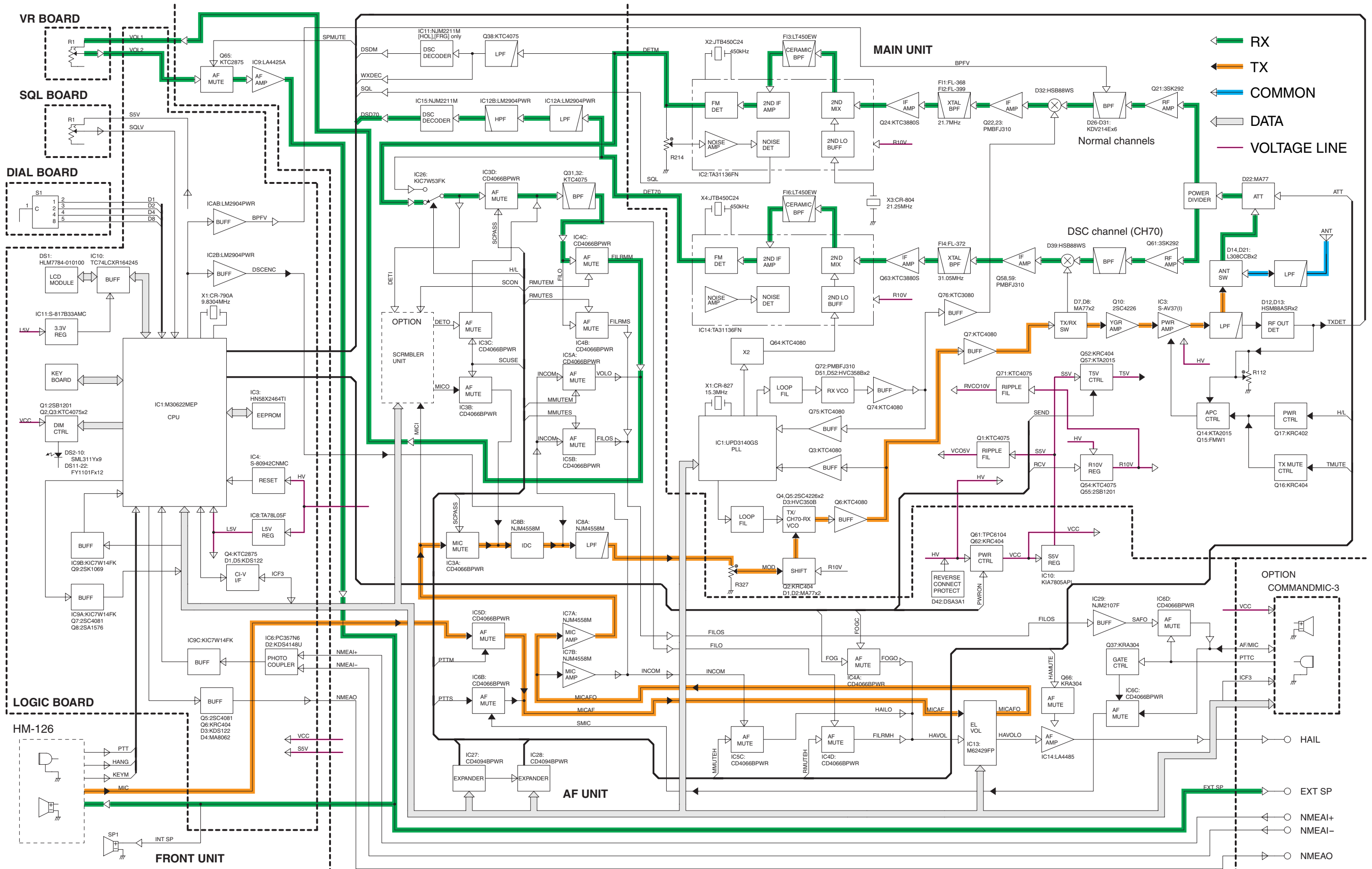

SECTION 11 VOLTAGE DIAGRAMS

11-1 FRONT UNIT

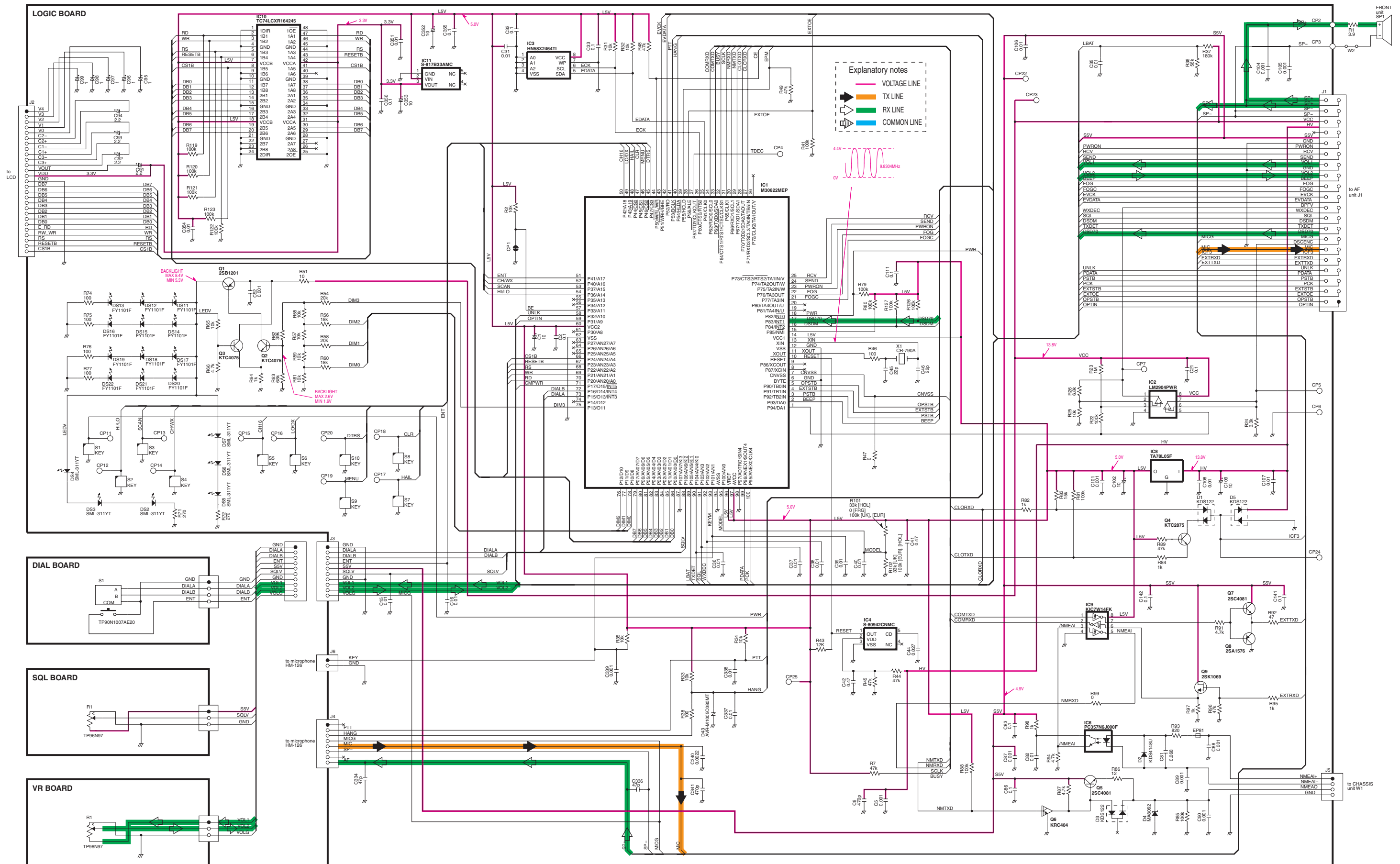

11-2 AF UNIT

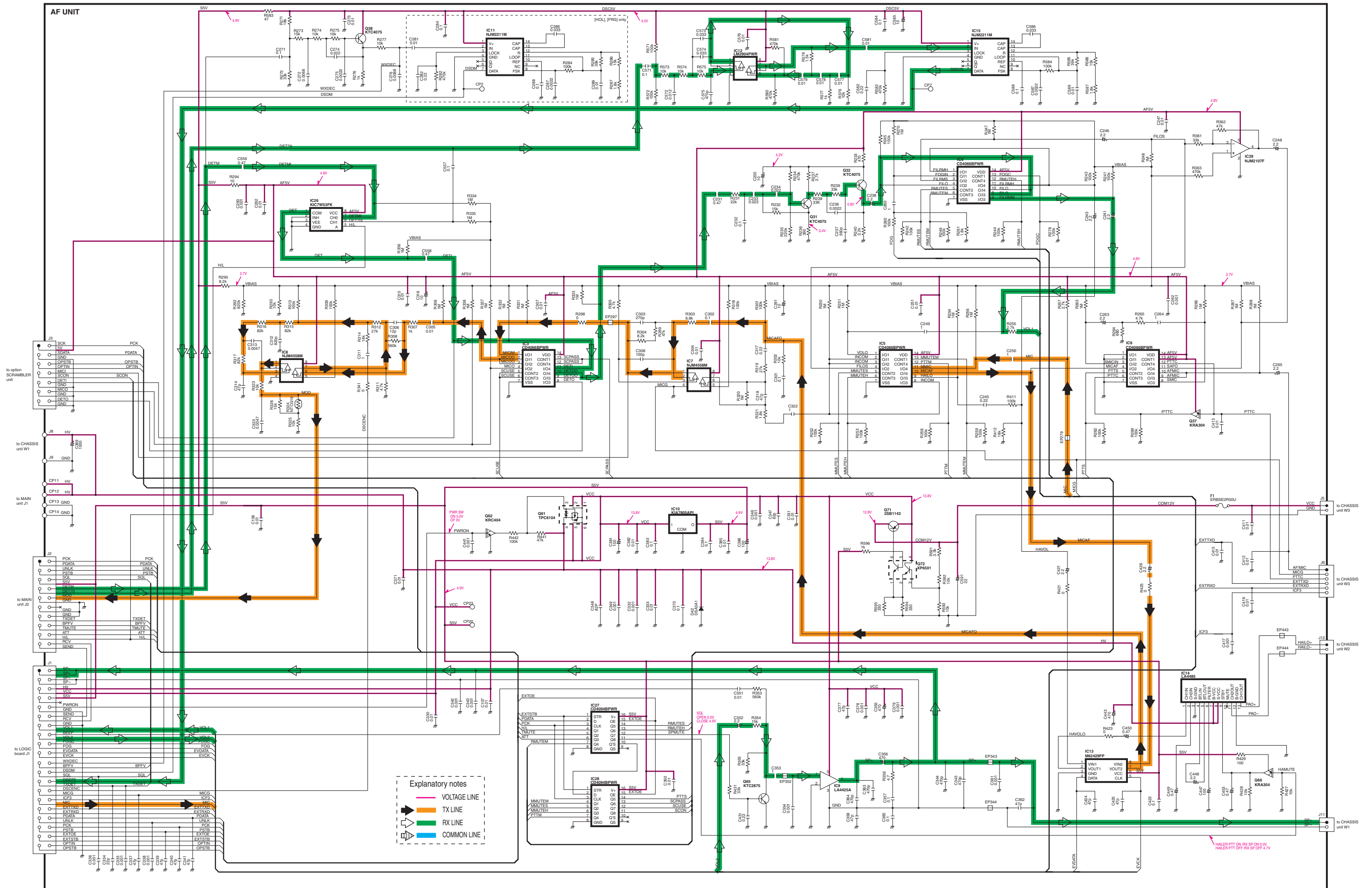

11-3 MAIN UNIT

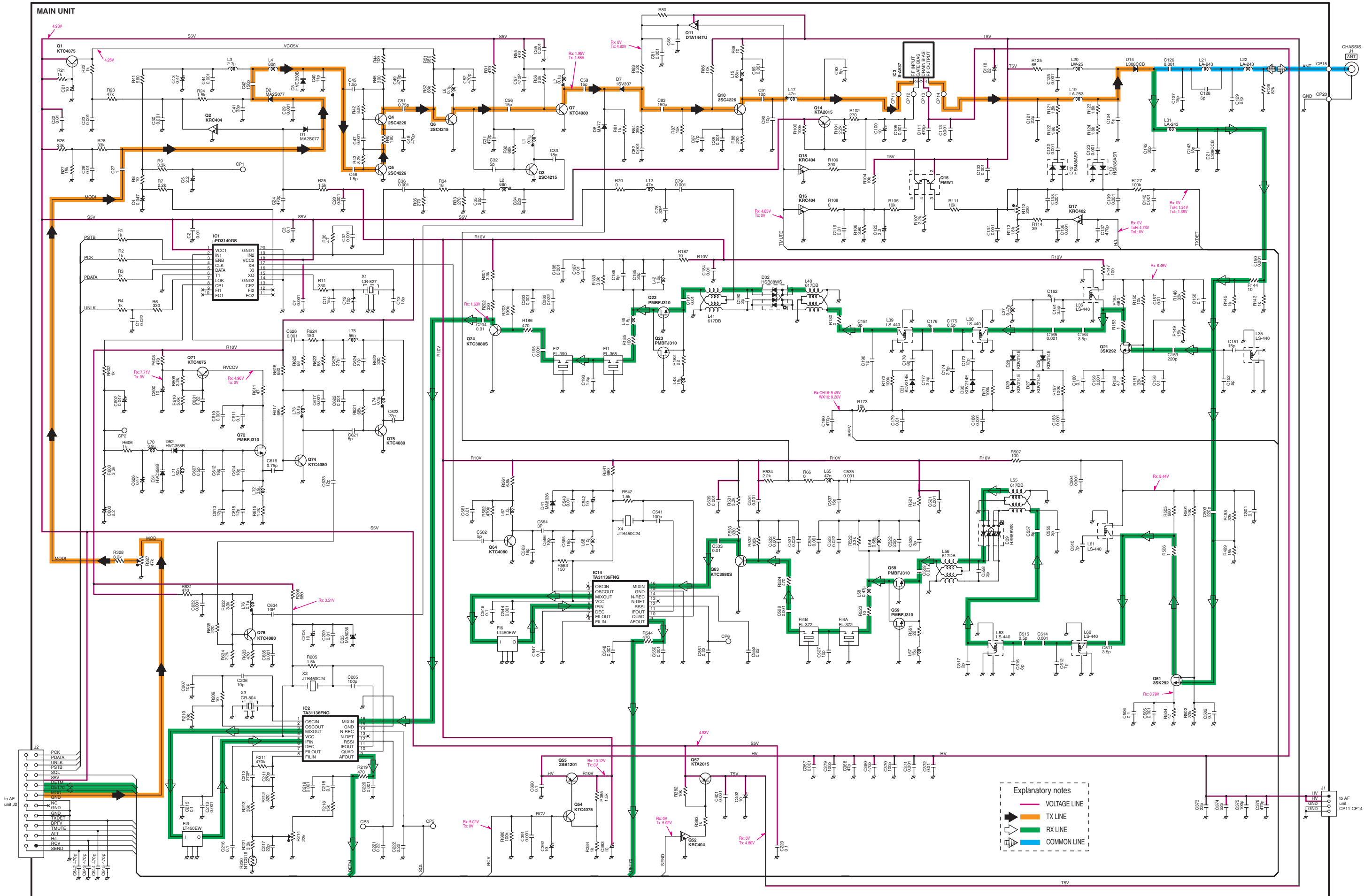

Icom Inc.

1-1-32, Kamiminami, Hirano-ku, Osaka 547-0003, Japan
Phone : +81 (06) 6793 5302
Fax : +81 (06) 6793 0013
URL : <http://www.icom.co.jp/world/index.html>

Icom America Inc.

<Corporate Headquarters>
2380 116th Avenue N.E., Bellevue, WA 98004, U.S.A.
Phone : +1 (425) 454-8155 Fax : +1 (425) 454-1509
URL : <http://www.icomamerica.com>
E-mail : sales@icomamerica.com
<Customer Service>
Phone : +1 (425) 454-7619

Icom Canada

Glenwood Centre #150-6165
Highway 17 Delta, B.C., V4K 5B8, Canada
Phone : +1 (604) 952-4266 Fax : +1 (604) 952-0090
URL : <http://www.icomcanada.com>
E-mail : info@icomcanada.com

Icom (Australia) Pty. Ltd.

Unit 1 / 103 Garden Road, Clayton VIC 3168 Australia
Phone : +61 (03) 9549-7500 Fax : +61 (03) 9549-7505
URL : <http://www.icom.net.au>
E-mail : sales@icom.net.au

Icom New Zealand

146A Harris Road, East Tamaki,
Auckland, New Zealand
Phone : +64 (09) 274 4062 Fax : +64 (09) 274 4708
URL : <http://www.icom.co.nz>
E-mail : inquiries@icom.co.nz

Beijing Icom Ltd.

10C07, Long silver Mansion, No.88, Yong Ding
Road, Haidian District, Beijing, 100039, China
Phone : +86 (010) 5889 5391/5392/5393
Fax : +86 (010) 5889 5395
E-mail : bjicom@bjicom.com
URL : <http://www.bjicom.com>

Icom (Europe) GmbH

Communication Equipment
Himmelgeister Str. 100, D-40225 Düsseldorf, Germany
Phone : +49 (0211) 346047 Fax : +49 (0211) 333639
URL : <http://www.icomeurope.com>
E-mail : info@icomeurope.com

Icom Spain S.L

Ctra. Rubi, 88, 08190, Sant Cugat del Valles, Barcelona, SPAIN
Phone : +34 (93) 590 26 70 Fax : +34 (93) 589 04 46
URL : <http://www.icomspain.com>
E-mail : icom@icomspain.com

Icom (UK) Ltd.

Unit 9, Sea St., Herne Bay, Kent, CT6 8LD, U.K.
Phone : +44 (01227) 741741 Fax : +44 (01227) 741742
URL : <http://www.icomuk.co.uk>
E-mail : info@icomuk.co.uk

Icom France s.a.s.

Zac de la Plaine
1 Rue Brindejonn des Moulinais BP 5804
31505 Toulouse Cedex, France
Phone : +33 (5) 61 36 03 03 Fax : +33 (5) 61 36 03 00
URL : <http://www.icom-france.com>
E-mail : icom@icom-france.com

Asia Icom Inc.

6F No.68, Sec. 1 Cheng-Teh Road, Taipei, Taiwan, R.O.C.
Phone : +886 (02) 2559 1899 Fax : +886 (02) 2559 1874
URL : <http://www.asia-icom.com>
E-mail : sales@asia-icom.com

Icom Polska

Sopot, 3 Maja 54 Poland
Phone : +48 (58) 550 7135 Fax : +48 (58) 551 0484
E-mail : icompolska@icompolska.com.pl

Count on us!

Icom Inc.

1-1-32, Kamiminami, Hirano-ku, Osaka 547-0003, Japan

S-14226HZ-C1
© 2006 Icom Inc.